

# ANDERSON GREENWOOD INSTRUMENTATION PRODUCTS

## Hand Valves and Accessories



**Soft Seated Valves**  
**Hard Seated Valves**  
**Mini Valves**

Anderson Greenwood is the industry leader in instrument valve technology and the original innovator of the 3-valve manifold. Our capabilities include over 50 years of research, design and manufacture of instrumentation products. Our products are designed to be maintenance free, and are offered with numerous configurations, materials, end connections and special requirements.

Anderson Greenwood Instrumentation Products is a registered trademark of Tyco International Services AG or its affiliates in the United States and/or other countries. All other brand names, product names, or trademarks belong to their respective holders.

## Contents

### Bonnet Technology

Bonnet Assemblies . . . . .	1 - 2
-----------------------------	-------

### Soft Seated Hand Valves

#### H1 3/16-inch and 1/4-inch

Product Overview - Features and Benefits . . . . .	3
Dimensions . . . . .	4 - 5
Materials . . . . .	6
Flow Characteristics . . . . .	7
Pressure/Temperature Ratings . . . . .	8 - 9
Ordering Information . . . . .	10 - 11

#### H1 3/8-inch

Product Overview - Features and Benefits . . . . .	12
Dimensions . . . . .	13
Materials, Pressure/Temperature Ratings . . . . .	14
Flow Characteristics . . . . .	15
Ordering Information . . . . .	16

### Hard Seated Hand Valves

#### H7 and H71 3/16-inch

Product Overview - Features and Benefits . . . . .	17
Dimensions, Materials . . . . .	18 - 19
Pressure/Temperature Ratings . . . . .	20
Options . . . . .	21
Ordering Information . . . . .	22 - 23

#### H7 3/16-inch ASME B31.1 and B31.3

Product Overview - Features and Benefits . . . . .	24
Pressure/Temperature Ratings . . . . .	25
Ordering Information . . . . .	26

### Globe Pattern Hand Valves

#### HM25H 5/16-inch

Product Overview - Features and Benefits . . . . .	27
Dimensions, Pressure/Temperature Ratings . . . . .	28
Ordering Information . . . . .	29

#### HM25D 7/16-inch

Product Overview - Features and Benefits . . . . .	30
Dimensions, Pressure/Temperature Ratings . . . . .	31
Ordering Information . . . . .	32

**Roddable Hand Valves**

**HM1C  $\frac{5}{8}$ -inch**

Product Overview - Features and Benefits .....	33
Dimensions, Pressure/Temperature Ratings .....	34
Ordering Information .....	34

**Mini Valves**

**H5 6000 psig**

Product Overview - Features and Benefits .....	35
Dimensions .....	36
Materials, Flow Characteristics .....	37
Pressure/Temperature Ratings .....	38 - 39
Options .....	40
Ordering Information .....	41

**Accessories**

**CT7 Gauge Siphon**

Product Overview - Features and Benefits .....	42
Dimensions, Materials .....	43
Heat Loss Data .....	44

**GA-HP Gauge Adapter**

Product Overview - Features and Benefits .....	45
Specifications and Ordering Information .....	46

**FCA Flow Check Adapter**

Product Overview - Features and Benefits .....	47
Specifications and Ordering Information .....	48

## Bonnet Technology

### Soft-Seated Bonnet Assembly

The soft-seated bonnet assembly has a one-piece rotating stem and plug. The stem threads are rolled and lubricated to prevent galling and reduce operating torque. Available with a patented PTFE packing gland, which is adjustable in service, or with a Viton® O-ring and PTFE back-up ring. A protective dust cap is fitted to contain stem lubricant and prevent the influx of contaminants. The standard hand valves have either  $\frac{3}{16}$ -inch [4.8 mm] or  $\frac{1}{4}$ -inch [6.4 mm] diameter orifice size. All bonnets are assembled with a bonnet locking pin to prevent accidental removal while in service.

### Metal-Seated Bonnet Assembly

The metal-seated bonnet assembly has a rotating stem with free swivel ball-type seat for long service life. The stem threads are rolled and lubricated to prevent galling and reduce operating torque. The stem seal is a patented PTFE packing gland which is adjustable in service. A protective dust cap is fitted to contain stem lubricant and prevent the influx of contaminants. The specially hardened ball seat is ideal for both gas and liquid service. All bonnets are assembled with a bonnet locking pin to prevent accidental removal while in service.

The 10,000 psig [689 barg] bonnet assembly uses a strengthened stem and bonnet. The stem seal is a patented PTFE packing gland which is adjustable in service. A protective dust cap is fitted to contain stem lubricant and prevent the influx of contaminants. This bonnet is also fitted with a larger size T-bar handle.

The high-temperature bonnet assemblies utilizes a similarly designed stem and bonnet, and incorporates adjustable GRAFOIL® O-rings and back-up pressure rings to ensure a leak-free stem seal.

### Notes

1. Viton® is a registered trademark of E.I. duPont de Nemours and Company.
2. GRAFOIL® is a registered trademark of GrafTech, Inc.

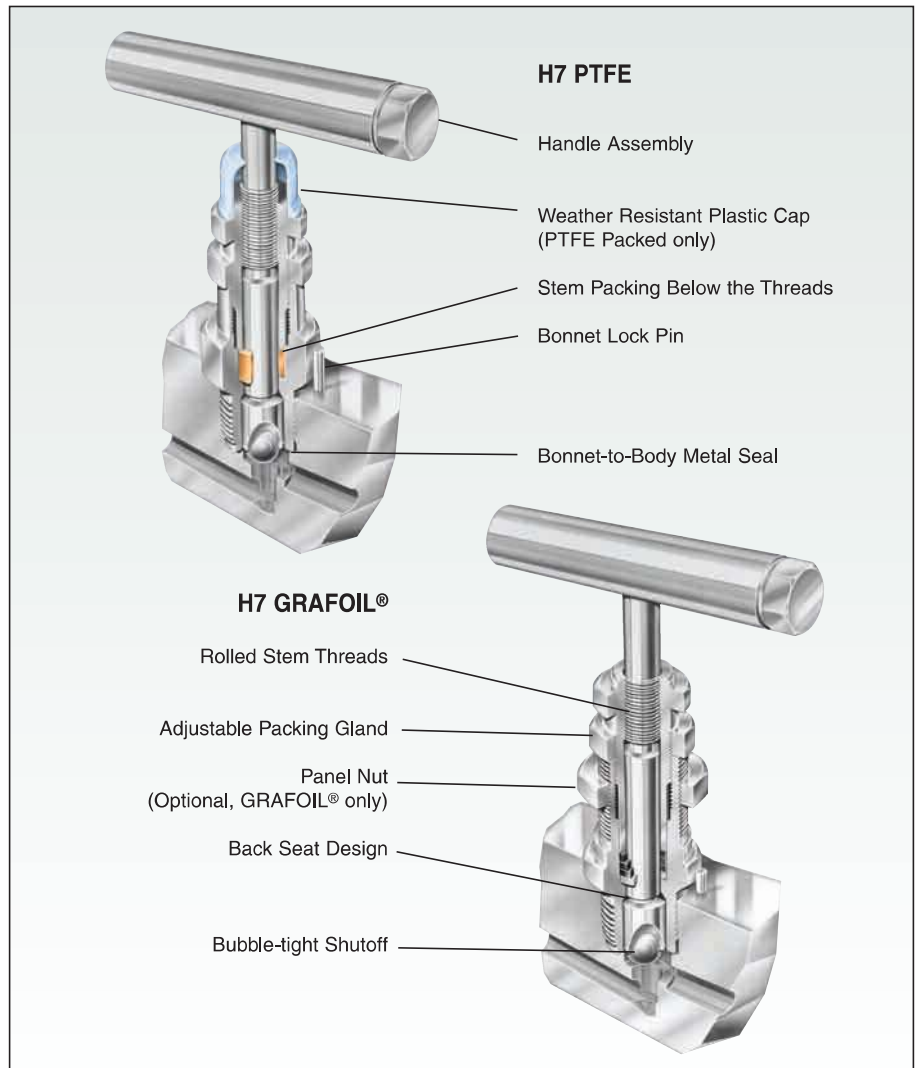
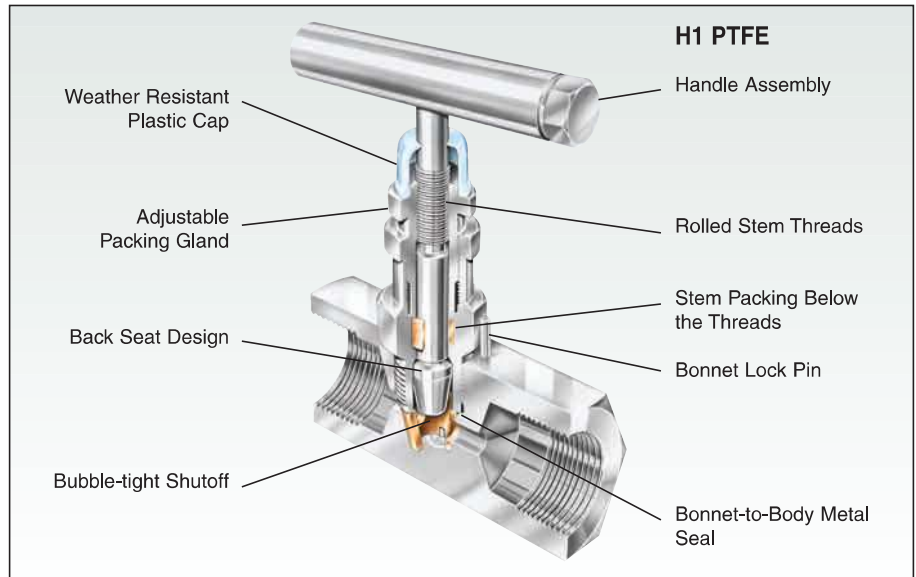

## Bonnet Technology, continued

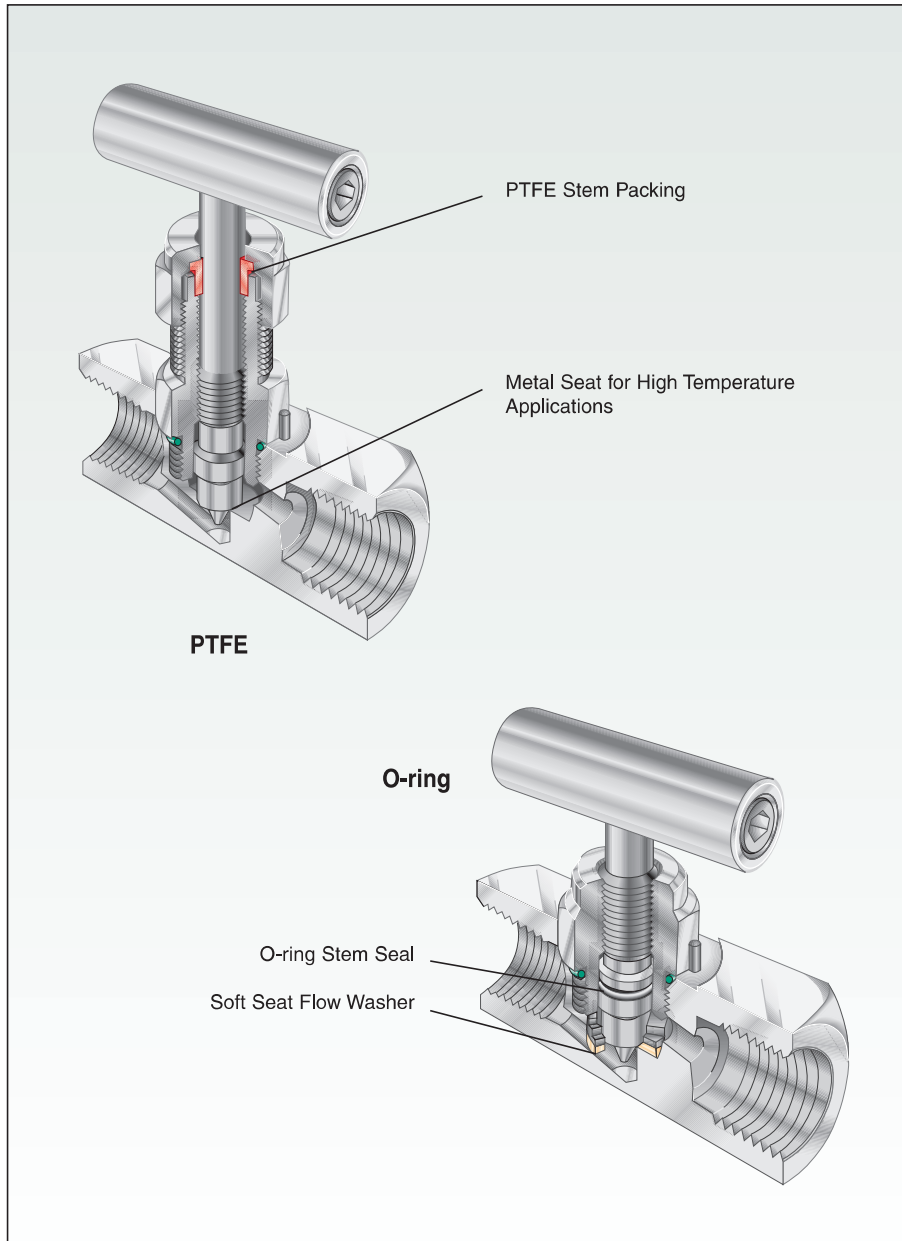

### Mini-Valve Bonnet Assembly

The mini-valve bonnet assembly has a compact design with a one-piece rotating stem which is 'V' tipped with a shoulder for use as a metal or soft seated valve. The stem threads are rolled and lubricated to prevent galling and reduce operating torque.

The mini-valve bonnet comes in three designs. An adjustable PTFE stem packed bonnet is suitable for panel mounting via external bonnet threads. The O-ring bonnet assemblies use a Viton® O-ring seal below the stem thread.

A GRAFOIL® packed bonnet suitable for temperatures of up to 500°F [260°C] is available for SS valves only.

### Arctic Lube

The low temperature rating for standard Anderson Greenwood carbon steel and 316 stainless steel instrumentation products is -20°F [-28°C] (standard products - standard lubrication). Our -AL (Arctic Lube) option extends the lower temperature limit to -70°F [-57°C] on all stainless steel models.

## Soft Seated Hand Valves – H1

$\frac{3}{16}$ -inch [4.8 mm] and  $\frac{1}{4}$ -inch [6.4 mm] Orifice: 6000 and 10,000 psig [414 and 689 barg]

### Product Overview

The H1 Series valves are designed for maximum system reliability. The design criteria includes repetitive bubble-tight closure, safety, and a long, trouble-free life with easy maintenance.

Anderson Greenwood utilizes a replaceable soft seat that gives premium tightness at closure, even in dirty service. The H1's straight-through rising plug design provides high capacity with bi-directional flow, and is also roddable for easy cleaning.

These valves are standard with a variety of end connections, seat materials, and stem packing, in SS or CS, and are available to meet the requirements of NACE. All valves are 100 percent pressure tested with material traceability of the body available on request.

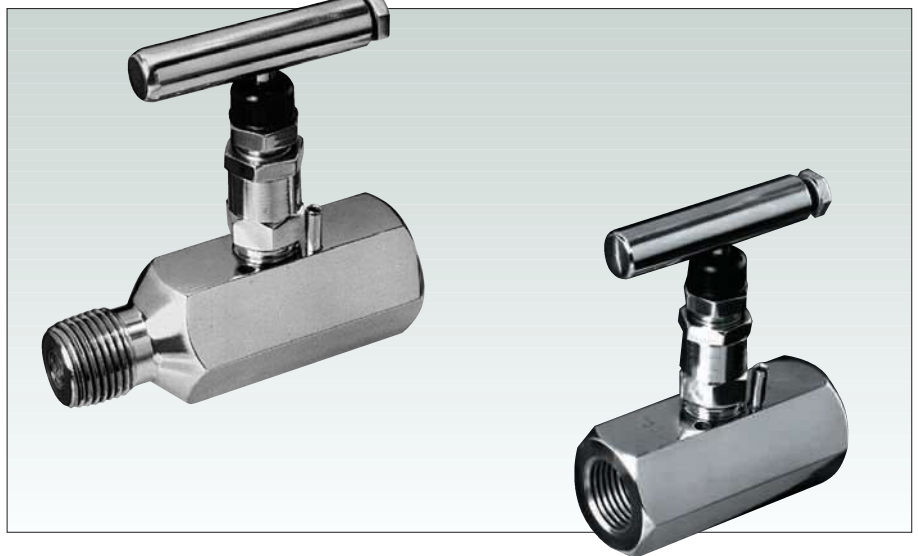

### Features and Benefits

- **Replaceable soft seat** allows replacement of the soft seat insert without removing the valve from the line. It operates in dirty service with repetitive bubble-tight shutoff.
- **Packing below threads** prevents lubricant washout, thread corrosion, and keeps solids from entering the thread area, which can cause galling. It also prevents process contamination.
- **Adjustable Teflon® packing** adjusts easily: loosen jam nut, tighten bushing slightly, then retighten jam nut. Decreases packing replacement downtime and increases valve life.
- **Dust cover** prevents lubricant washout and keeps contaminants (dirt, rain, etc.) out of bonnet assembly.
- **Safety back seating** prevents stem blowout or accidental removal while in operation and provides a metal-to-metal secondary stem seal while in the full open position.
- **Chrome plating of 316 SS stem** prevents galling or freezing of stem threads when similar metals mate. CS valves use a 303 SS stem.
- **Rolled threads** provide additional thread strength. The stem, bonnet, and male NPT threads are rolled, not cut.
- **Mirror stem finish** burnished to a 16 RMS finish in the packing area enables smooth stem operation and extends packing life.
- **Straight-through flow path** provides high flow capacity, bi-directional flow, and rodding capabilities.
- **Body-to-bonnet seal** is metal-to-metal in constant compression below the bonnet threads. Prevents bonnet thread corrosion, eliminates possible tensile breakage of bonnet, and gives a reliable seal point.

### Note

1. Teflon® is a registered trademark of E.I. duPont de Nemours and Company.

## H1 Specifications<sup>3</sup>

$\frac{3}{16}$ -inch [4.8 mm] and  $\frac{1}{4}$ -inch [6.4 mm] Orifice: 6000 psig [414 barg]

### Dimensions, inches [mm]

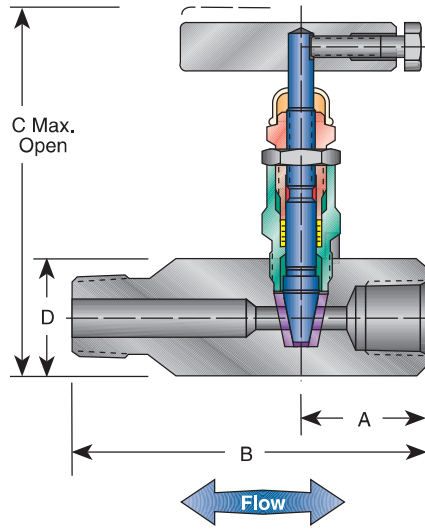
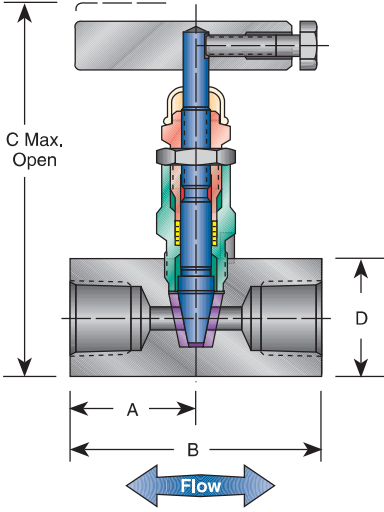

### FNPT by FNPT

Valve <sup>1</sup>	A	B	C <sup>2</sup>	D
$\frac{1}{4}$ " F x $\frac{1}{4}$ " F	1.05 [26.7]	2.10 [53.3]	3.70 [94.0]	1.00 [25.4]
$\frac{1}{2}$ " F x $\frac{1}{2}$ " F	1.35 [34.3]	2.70 [68.6]	3.85 [97.8]	1.25 [31.7]

### FNPT by MNPT

Valve <sup>1</sup>	A	B	C <sup>2</sup>	D
$\frac{1}{4}$ " F x $\frac{1}{4}$ " M	1.18 [30.0]	3.50 [88.9]	3.70 [94.0]	1.00 [25.4]
$\frac{1}{4}$ " F x $\frac{1}{2}$ " M	1.18 [30.0]	3.50 [88.9]	3.70 [94.0]	1.00 [25.4]
$\frac{1}{2}$ " F x $\frac{1}{2}$ " M	1.35 [34.3]	3.50 [88.9]	3.85 [97.8]	1.25 [31.7]

### Notes

1. Approximate valve weight: 1.3 lb [0.6 kg].
2. Valve  $C_v$  maximum  
 $\frac{3}{16}$ -inch [4.8 mm] – 0.83.  
 $\frac{1}{4}$ -inch [6.4 mm] – 1.40.
3. For Hastelloy® and -SG3 call factory for dimensions and weights.
4. Hastelloy is a registered trademark of Haynes International.

### FNPT by MNPT (Angle)

Valve	A	B	C
$\frac{1}{2}$ " F x $\frac{1}{2}$ " M	1.73 [43.9]	1.40 [35.6]	5.00 [127.0]

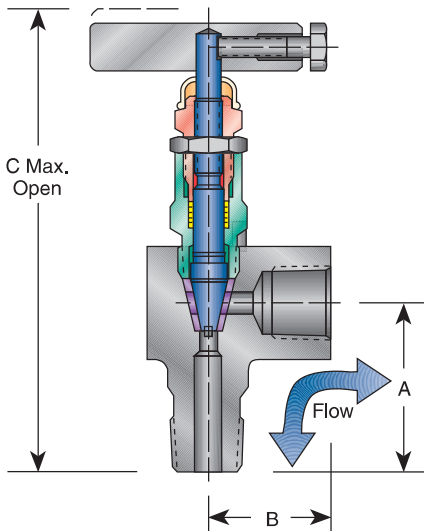

## H1 Specifications<sup>3</sup>

1/4-inch [6.4 mm] Orifice: 10,000 psig [689 barg]

### Dimensions, inches [mm]

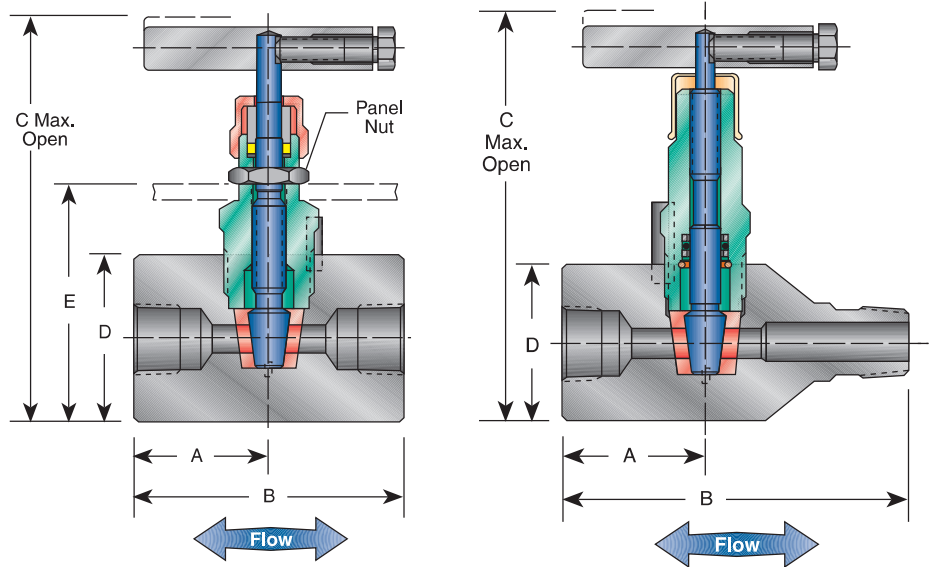

### Dimensions

Valve <sup>1</sup>	A	B	C <sup>2</sup>	D	E
O-ring Packed, Teflon® Packed 1/2" F x 1/2" F	1.50 [38.1]	3.00 [76.2]	4.82 [122.4]	1.75 [44.5]	1.98 [50.3]
O-ring Packed 1/2" F x 1/2" M	1.38 [35.1]	3.70 [94.0]	4.82 [122.4]	1.75 [44.5]	— —

### Notes

1. Approximate valve weight:  
Female x Female 2.7 lb [1.2 kg].  
Male x Female 3.0 lb [1.3 kg].
2. Valve C<sub>v</sub> 1.4 maximum.
3. For Hastelloy® and -SG3 call factory for dimensions and weights.



## H1 Specifications

### Standard Materials

H1 – 3/16-inch [4.8 mm] and 1/4-inch [6.4 mm] Orifice: 6000 psig [414 barg]

Valve	Body and Bonnet <sup>1</sup>	Stem	Packing <sup>2</sup>	Seat <sup>3</sup>
CS	A108	A581-303	Teflon® or Viton® O-ring with Teflon® backup ring	Delrin®
SS	A479-316	A276-316 Chrome Plated	Teflon® or Viton® O-ring with Teflon® backup ring	Delrin®
SG <sup>4</sup>	A479-316	Monel® 400	Teflon®	Delrin®
SG3 <sup>7</sup>	Hastelloy® C-276	Hastelloy® C-276	Teflon®	Delrin®

### Standard Materials

H1 – 1/4-inch [6.4 mm] Orifice: 10,000 psig [689 barg]

Valve	Body and Bonnet <sup>1</sup>	Stem	Packing <sup>2</sup>	Seat <sup>3</sup>
CS	A108	A581-303	Teflon® or Viton® O-ring with Teflon® backup ring	Delrin®
SS	A479-316	Monel® K500	Teflon® or Viton® O-ring with Teflon® backup ring	Delrin®
SG <sup>4</sup>	A479-316	Monel® K500	Teflon® or Viton® O-ring with Teflon® backup ring	Delrin®
SG3 <sup>7</sup>	Hastelloy® C-276	Hastelloy® C-276	Teflon® or Viton® O-ring with Teflon® backup ring	Delrin®

### Notes

1. CS is zinc cobalt plated to prevent corrosion.
2. Teflon® packing is patented.
3. PCTFE (Polychlorotrifluoroethylene is the exact equivalent of Kel-F®), PEEK, and Teflon® seats are also available.
4. SG (Sour Gas) meets the requirements of NACE MR0175/ISO 15156-3 Corrigendum 2 (for Chloride conditions ≤ 50 mg/l [ppm]) and NACE MR0103-2005.
5. Monel® is a registered trademark of Special Metals Corporation.
6. Delrin®, Kel-F® and Teflon® are all registered trademarks of E.I. duPont de Nemours and Company.
7. SG3 (Sour Gas) meets the requirements of NACE MR0175/ISO 15156-3 Corrigendum 2 (for Chloride conditions > 50 mg/l [ppm]).

## H1 Specifications

### Flow Characteristics – 3/16-inch [4.8 mm] and 1/4-inch [6.4 mm] Orifice

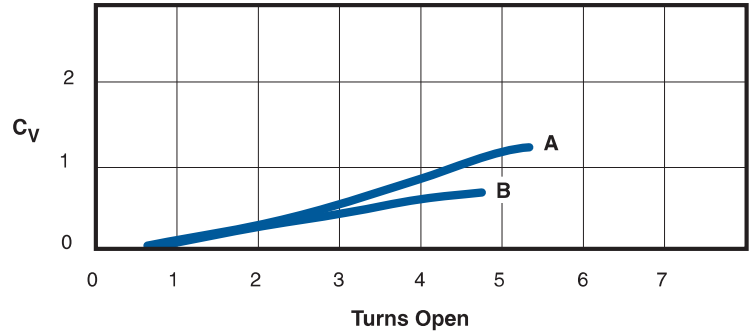

A = 1/4-inch [6.4 mm] orifice, valve  $C_v$  1.4 maximum  
B = 3/16-inch [4.8 mm] orifice, valve  $C_v$  .83 maximum

### Formulas

#### Liquids

$$Q_L = C_V \sqrt{\frac{(P_1 - P_2) (62.4)}{\rho}}$$

#### Gases (Where $P_2 > .5P_1$ )

$$Q_V = (23.18) C_V \sqrt{\frac{(P_1 - P_2) P_2}{(S.G.) T}}$$

#### Gases (Where $P_2 < .5P_1$ )

$$Q_V = \frac{(11.59) P_1 C_V}{\sqrt{S.G. (T)}}$$

#### Where:

- $Q_L$  = Flow (gpm)
- $Q_V$  = Flow (scfm)
- $\rho$  = Density of Liquid (lb/ft<sup>3</sup>)
- $P_1$  = Upstream Pressure (psia)
- $P_2$  = Downstream Pressure (psia)
- $T$  = Flowing Temperature (°R)  
(°R = °F + 460)
- $\rho$  (Water) = 62.4 lb/ft<sup>3</sup> @ 60°F [16°C]
- S.G. = Specific Gravity of Gas  
(M.W. of Air/28.96)
- S.G. Air = 1.000
- S.G. Nitrogen = 0.967
- S.G. Oxygen = 1.105
- S.G. Helium = 0.138
- S.G. Hydrogen = 0.0696

## H1 Specifications

3/16-inch [4.8 mm] and 1/4-inch [6.4 mm] Orifice: 6000 psig [414 barg]

### Pressure vs. Temperature

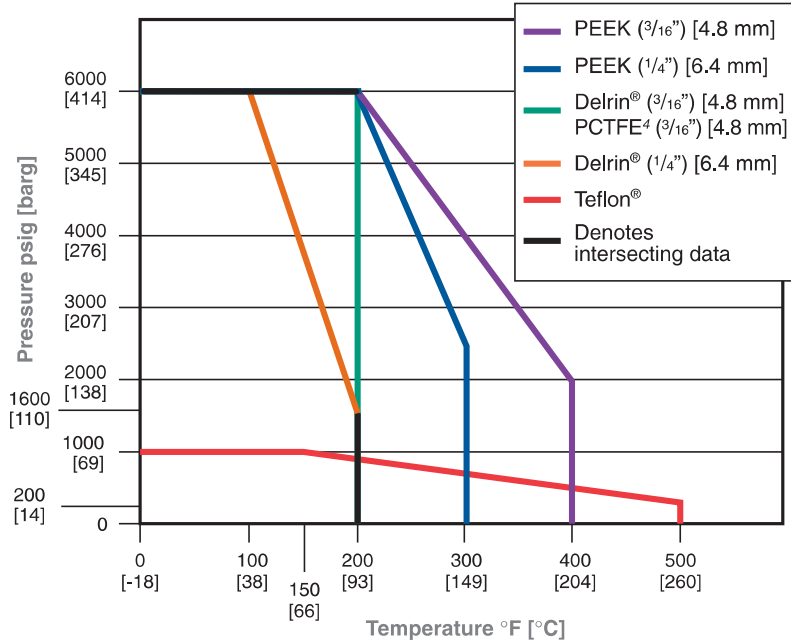

### Pressure and Temperature Ratings

Valve	3/16-inch [4.8 mm] Orifice	
Delrin® and PCTFE/ Seat	6000 psig @ 200°F	[414 barg @ 93°C]
PEEK Seat	6000 psig @ 200°F	[414 barg @ 93°C]
	2000 psig @ 400°F	[138 barg @ 204°C]
Teflon® Seat	1000 psig @ 150°F	[69 barg @ 66°C]
	200 psig @ 500°F	[14 barg @ 260°C]

Valve	1/4-inch [6.4 mm] Orifice	
Delrin® Seat	6000 psig @ 100°F	[414 barg @ 38°C]
	1600 psig @ 200°F	[110 barg @ 93°C]
PEEK Seat	6000 psig @ 200°F	[414 barg @ 93°C]
	2500 psig @ 300°F	[172 barg @ 149°C]

### Note

1. PCTFE (Polychlorotrifluoroethylene) is the exact equivalent of Kel-F®.

## H1 Specifications

1/4-inch [6.4 mm] Orifice: 10,000 psig [689 barg]

### Pressure vs. Temperature

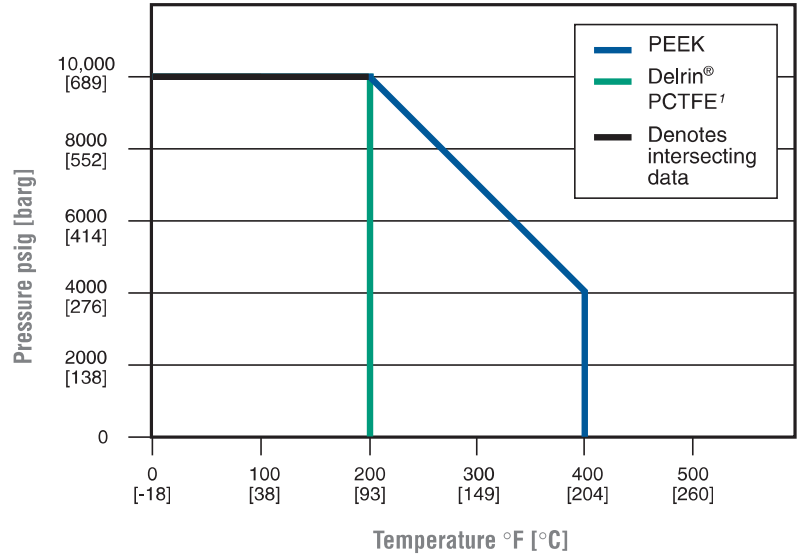

### Pressure and Temperature Ratings

Valve	1/4-inch [6.4 mm] Orifice	
Delrin® and PCTFE <sup>1</sup> Seat	10,000 psig @ 200°F	[689 barg @ 93°C]
PEEK Seat	10,000 psig @ 200°F	[689 barg @ 93°C]
	4,000 psig @ 400°F	[276 barg @ 204°C]

### Note

1. PCTFE (Polychlorotrifluoroethylene) is the exact equivalent of Kel-F®.

## H1 Specifications

3/16-inch [4.8 mm] and 1/4-inch [6.4 mm] Orifice: 6000 psig [414 barg]

### Ordering Information

	H1	V	D	S	- 44Q	- SG
<b>Packing</b>						
V - Teflon®						
R - Viton® O-ring with Teflon® backup ring						
<b>Seat</b>						
D - Delrin® (standard)						
K - PCTFE <sup>1</sup>						
E - PEEK						
V - Teflon®						
<b>Material</b>						
C - CS						
S - 316 SS						
M - Monel® (Teflon® packed only)						
J - Hastelloy®						
Special alloys available on request.						
<b>Connections (Bidirectional)</b>						
<b>3/16-inch [4.8 mm] Orifice</b>						
2 - 1/4-inch F x 1/4-inch F						
22 - 1/4-inch F x 1/4-inch M						
24 - 1/4-inch F x 1/2-inch M						
4Q - 1/2-inch F x 1/2-inch F						
44Q - 1/2-inch F x 1/2-inch M						
44QA - 1/2-inch F x 1/2-inch M (Angle)						
<b>1/4-inch [6.4 mm] Orifice (Delrin® and PEEK Seats only)</b>						
4QR - 1/2-inch F x 1/2-inch F						
44QR - 1/2-inch F x 1/2-inch M						
<b>Options</b>						
AL - Arctic Lubricant (low temperature service -70°F) - not available for CS valves						
BL - Bonnet Lock Device (patent protected) (page 21)						
PHB - Phenolic Black Round Handle						
SG - (Sour Gas) meets the requirements of NACE MR0175/ISO 15156-3 Corrigendum 2 (for Chloride conditions ≤ 50 mg/l [ppm]) and NACE MR0103-2005 (316 SS only)						
SG3 - (Sour Gas) meets the requirements of NACE MR0175/ISO 15156-3 Corrigendum 2 (for Chloride conditions > 50 mg/l [ppm])						
SP - Special Requirements - please specify						

### Note

1. PCTFE (Polychlorotrifluoroethylene) is the exact equivalent of Kel-F®.

## H1 Specifications

H1 1/4-inch [6.4 mm] Orifice: 10,000 psig [689 barg]

### Ordering Information

	H1	V	D	C	- 4R10	- SP
<b>Packing</b>						
		V – Teflon® (Packed bonnet available in CS only) R – Viton® O-ring with Teflon® backup ring				
<b>Seat</b>						
		D – Delrin® (standard) K – PCTFE <sup>1</sup> E – PEEK				
<b>Body Materials</b>						
		C – CS S – 316 SS J – Hastelloy®				
<b>Connections (Bidirectional)</b>						
		4R10 – 1/2-inch F x 1/2-inch F 44R10 – 1/2-inch M x 1/2-inch F				
<b>Options</b>						
		AL – Arctic Lubricant (low temperature service -70°F) - not available for CS valves SG – (Sour Gas) meets the requirements of NACE MR0175/ISO 15156-3 Corrigendum 2 (for Chloride conditions ≤ 50 mg/l [ppm]) and NACE MR0103-2005 (316 SS only) SG3 – (Sour Gas) meets the requirements of NACE MR0175/ISO 15156-3 Corrigendum 2 (for Chloride conditions > 50 mg/l [ppm]) SP – Special Requirements - please specify				

### Note

1. PCTFE (Polychlorotrifluoroethylene) is the exact equivalent of Kel-F®.

## Large Bore Hand Valves – H1

$\frac{3}{8}$ -inch [9.5 mm] Diameter Orifice, General Purpose Valve



### Product Overview

The  $\frac{3}{8}$ -inch [9.5 mm] general purpose, soft-seated hand valve is designed for safe, repetitive bubble-tight closure, simple maintenance, and a long, reliable cycle life.

For premium tightness at closure, even in dirty service, a replaceable soft seat is incorporated on these valves. The straight-through, rising-plug design provides high capacity with bi-directional flow, and is roddable for easy cleaning.

This valve is standard with a variety of end connections, seat materials, and stem packing, in SS or CS, and is available to meet the requirements of NACE. All valves are 100 percent pressure tested with material traceability of the body available on request.

### Features and Benefits

- **Replaceable soft seat** allows replacement of the soft seat insert without removing the valve from the line. It operates in dirty service with repetitive bubble-tight shutoff.
- **Packing below threads** prevents lubricant washout, thread corrosion, and keeps solids from entering the thread area, which can cause galling. It also prevents process contamination.
- **Dust cover** prevents lubricant washout and keeps contaminants (dirt, rain, etc.) out of bonnet assembly.
- **Safety back seating** prevents stem blowout and accidental removal while in operation.
- **Chrome plating of 316 SS stem** prevents galling or freezing of stem threads when similar metals mate. CS valves use a 303 SS stem.
- **Rolled threads** provide additional thread strength. The stem, bonnet, and male NPT threads are rolled, not cut.
- **Mirror stem finish** burnished to a 16 RMS finish in the packing area enables smooth stem operation and extends packing life.
- **Straight-through flow path** provides high flow capacity, bi-directional flow, and rodding capabilities.
- **Body-to-bonnet seal** is metal-to-metal in constant compression, isolating the bonnet threads from process fluid corrosion. Eliminates possible tensile breakage of bonnet, and gives a reliable seal point.

## H1 Specifications<sup>2</sup>

<sup>3</sup>/<sub>8</sub>-inch [9.5 mm] Diameter Orifice

Dimensions, inches [mm]

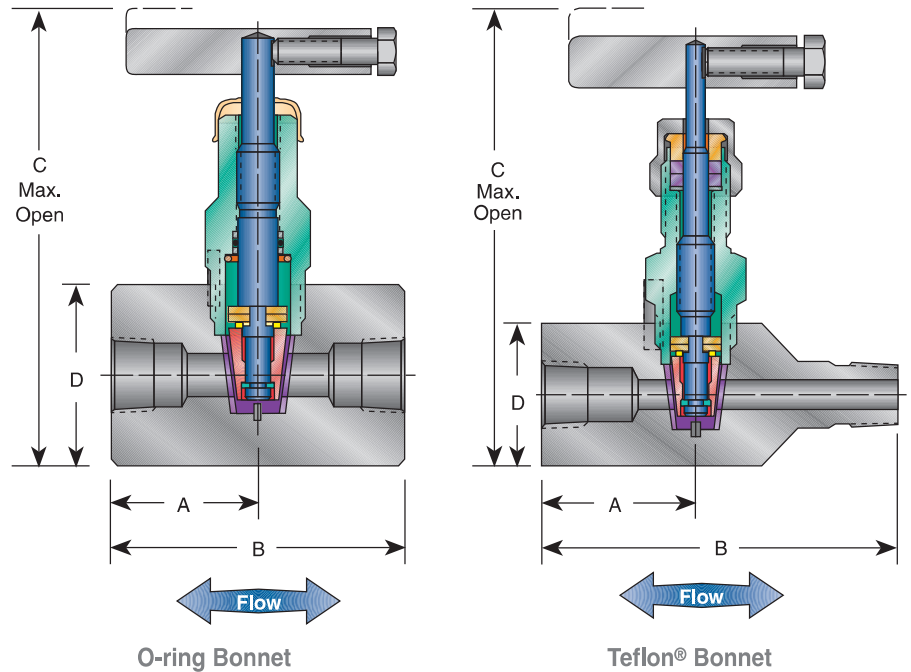

### Dimensions

End Connection <sup>1</sup>	A	B	C O-ring	C Teflon®	D	Valve Weight lb [kg]
1/2" F x 1/2" F	1.50 [38.1]	3.00 [76.2]	5.76 [146.3]	5.49 [139.4]	1.75 sq [44.5]	3.6 [1.6]
1/2" M x 1" F	1.88 [47.6]	4.38 [111.3]	5.76 [146.3]	5.49 [139.4]	1.75 sq [44.5]	3.6 [1.6]
3/4" F x 3/4" F	2.00 [50.8]	4.00 [101.6]	6.26 [159.0]	6.00 [152.4]	2.25 hex [57.2]	5.4 [2.5]
3/4" M x 3/4" F	2.00 [50.8]	5.00 [127.0]	6.26 [159.0]	6.00 [152.4]	2.25 hex [57.2]	5.4 [2.5]
1" F x 1" F	2.00 [50.8]	4.00 [101.6]	6.26 [159.0]	6.00 [152.4]	2.25 hex [57.2]	5.4 [2.5]
1" M x 1" F	2.00 [50.8]	5.00 [127.0]	6.26 [159.0]	6.00 [152.4]	2.25 hex [57.2]	5.4 [2.5]

### Notes

1. Valve C<sub>v</sub> 3.0 maximum.
2. For Hastelloy® and -SG3 call factory for dimensions and weights.



## H1 Specifications

<sup>3</sup>/<sub>8</sub>-inch [9.5 mm] Orifice

### Standard Materials

Valve	Body and Bonnet	Stem	Packing	Seat <sup>2</sup>
CS <sup>1</sup>	A108 <sup>1</sup>	A581-303	Teflon® or BUNA-N O-ring with Teflon® backup ring	Delrin®
SS	A479-316	A276-316	Teflon® or Viton® O-ring with Teflon® backup ring	Delrin®
SG <sup>3</sup>	A479-316	Monel® R405	Teflon® or Viton® O-ring with Teflon® backup ring	Delrin®
SG3 <sup>5</sup>	Hastelloy® C-276	Hastelloy® C-276	Teflon® or Viton® O-ring with Teflon® backup ring	Delrin®

### Notes

1. CS is zinc cobalt plated to prevent corrosion.
2. PCTFE, PEEK, and Teflon® are available.
3. SG (Sour Gas) meets the requirements of NACE MR0175/ISO 15156-3 Corrigendum 2 (for Chloride conditions ≤ 50 mg/l [ppm]) and NACE MR0103-2005.
4. PCTFE (Polychlorotrifluoroethylene) is the exact equivalent of Kel-F®.
5. SG3 (Sour Gas) meets the requirements of NACE MR0175/ISO 15156-3 Corrigendum 2 (for Chloride conditions > 50 mg/l [ppm]).

### Pressure vs. Temperature

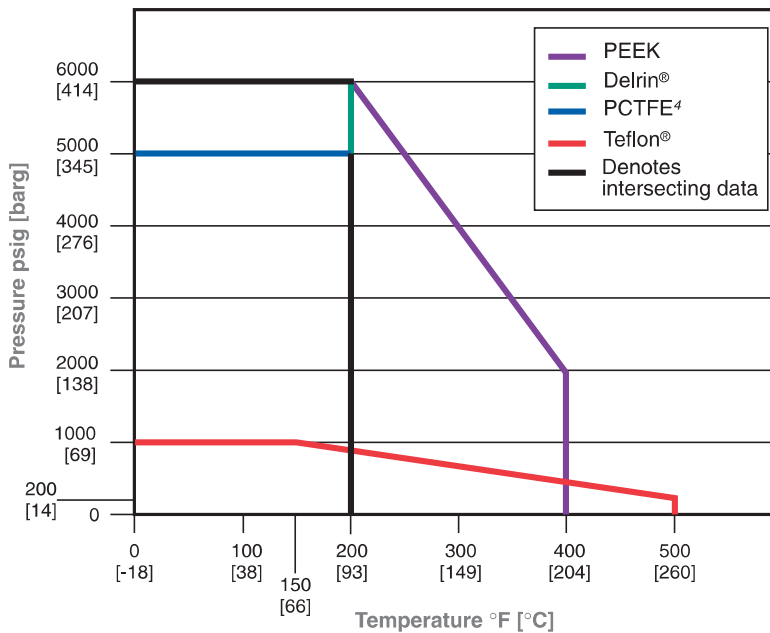

### Pressure and Temperature Ratings

#### Seat

Delrin®	6000 psig @ 200°F [414 barg @ 93°C]
PCTFE <sup>4</sup>	5000 psig @ 200°F [345 barg @ 93°C]
PEEK	6000 psig @ 200°F [414 barg @ 93°C] 2000 psig @ 400°F [138 barg @ 204°C]
Teflon®	1000 psig @ 150°F [69 barg @ 66°C] 200 psig @ 500°F [14 barg @ 260°C]

## H1 Specifications

<sup>3</sup>/<sub>8</sub>-inch [9.5 mm] Orifice

### Flow Characteristics

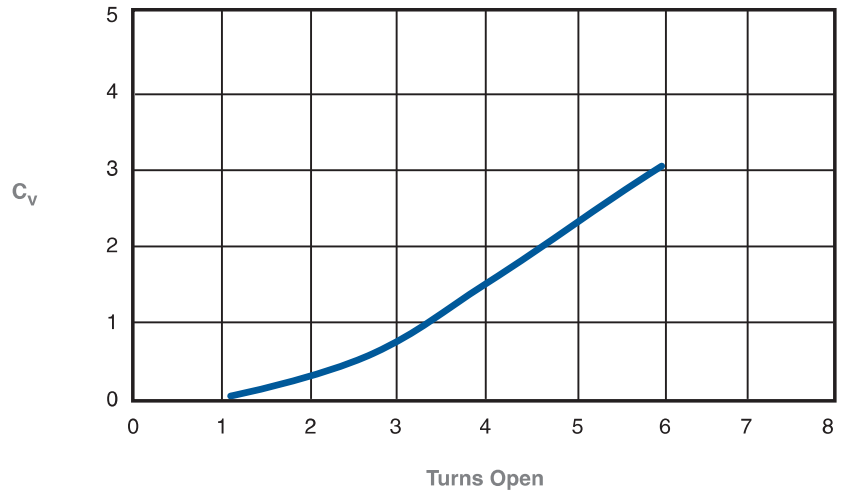

<sup>3</sup>/<sub>8</sub>-inch [9.5 mm] orifice, C<sub>v</sub> 3.0 maximum

### Formulas

#### Liquids

$$Q_L = C_V \sqrt{\frac{(P_1 - P_2) (62.4)}{\rho}}$$

#### Gases (Where P<sub>2</sub> > .5P<sub>1</sub>)

$$Q_V = (23.18) C_V \sqrt{\frac{(P_1 - P_2) P_2}{(S.G.) T}}$$

#### Gases (Where P<sub>2</sub> < .5P<sub>1</sub>)

$$Q_V = \frac{(11.59) P_1 C_V}{\sqrt{S.G. (T)}}$$

#### Where:

- Q<sub>L</sub> = Flow (gpm)
- Q<sub>V</sub> = Flow (scfm)
- ρ = Density of Liquid (lb/ft<sup>3</sup>)
- P<sub>1</sub> = Upstream Pressure (psia)
- P<sub>2</sub> = Downstream Pressure (psia)
- T = Flowing Temperature (°R)  
(°R = °F + 460)
- ρ (Water) = 62.4 lb/ft<sup>3</sup> @ 60°F [16°C]
- S.G. = Specific Gravity of Gas  
(M.W. of Air/28.96)
- S.G. Air = 1.000
- S.G. Nitrogen = 0.967
- S.G. Oxygen = 1.105
- S.G. Helium = 0.138
- S.G. Hydrogen = 0.0696

## H1 Specifications

<sup>3</sup>/<sub>8</sub>-inch [9.5 mm] Orifice

### Ordering Information

**H1                                  V                                  D                                  S                                  - 4                                  - SG**

#### Packing

- V - Teflon®
- R - Viton® O-ring with Teflon® backup ring

#### Seat

- D - Delrin® (standard)
- K - PCTFE<sup>1</sup>
- E - PEEK
- V - Teflon®

#### Material

- C - CS
- S - 316 SS
- J - Hastelloy®

#### Connections (Bidirectional)

- 4 - 1/2-inch F x 1/2-inch F
- 48 - 1/2-inch F x 1-inch M
- 6Q - 3/4-inch F x 3/4-inch F
- 66Q - 3/4-inch F x 3/4-inch M
- 8Q - 1-inch F x 1-inch F
- 88Q - 1-inch F x 1-inch M

#### Options

- AL - Arctic Lubricant (low temperature service -70°F) - not available for CS valves
- SG - (Sour Gas) meets the requirements of NACE MR0175/ISO 15156-3 Corrigendum 2 (for Chloride conditions ≤ 50 mg/l [ppm]) and NACE MR0103-2005 (316 SS only; Teflon® packed only)
- SG3 - (Sour Gas) meets the requirements of NACE MR0175/ISO 15156-3 Corrigendum 2 (for Chloride conditions > 50 mg/l [ppm])
- SP - Special Requirements - please specify

#### Note

1. PCTFE (Polychlorotrifluoroethylene) is the exact equivalent of Kel-F®.

## Hard Seated Hand Valves – H7 and H71

<sup>3</sup>/<sub>16</sub>-inch [4.8 mm], 6000 and 10,000 psig [414 and 689 barg]

### Product Overview

The H7 Series valves are designed for safe, repetitive bubble-tight closure, simple maintenance, and a long, trouble-free life. A free-swiveling ball end stem is incorporated for bubble-tight closure.

A variety of standard end connections and stem packing is available to meet the requirements of NACE. All valves are 100 percent pressure tested. Material traceability of the body is available on request.

Increasing pressures in oil and gas production have led to the development of the H71 valve. Rated to 10,000 psig [689 barg] @ 200°F [93°C], this valve provides long life and bubble-tight shutoff in severe operating conditions.

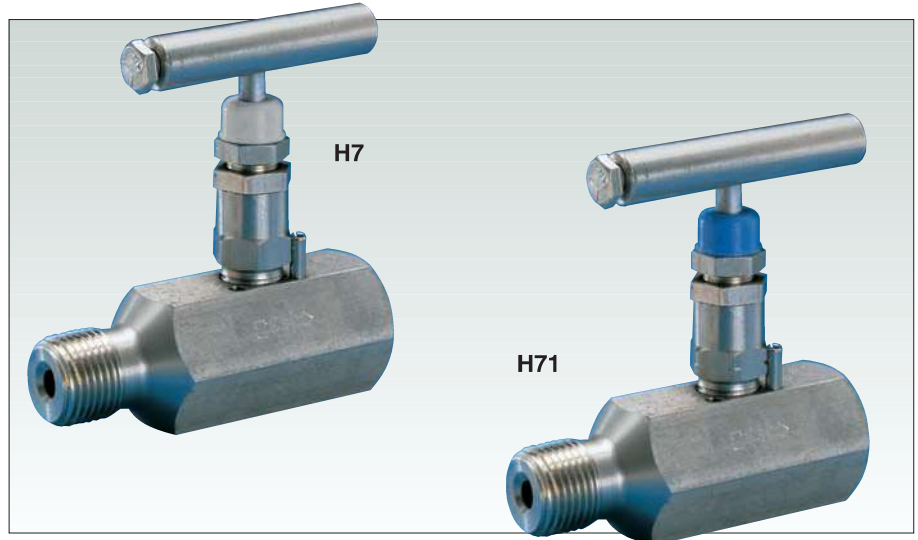

### Features and Benefits

- **Ball end stem** eliminates seat galling, provides bubble-tight shutoff and long life. The hardened, non-rotating ball ensures perfect alignment closure.
- **Packing below threads** prevents lubricant washout, thread corrosion, and keeps solids from entering the thread area, which can cause galling. It also prevents process contamination.
- **Adjustable packing** adjusts easily – loosen jam nut, tighten bushing slightly, then retighten jam nut. Decreases packing replacement downtime and increases valve life.
- **Dust cover** prevents lubricant washout and keeps contaminants (dirt, rain, etc.) out of bonnet assembly.
- **Safety back seating** prevents stem blowout or accidental removal while in operation and provides a metal-to-metal secondary stem seal while in the full open position.
- **Panel mount** (optional) affords opportunity to use high quality products in racks or panels.
- **Chrome plating of 316 SS** prevents galling or freezing of stem threads when similar metals mate. CS valves use a 303 SS stem.
- **Rolled threads** provide additional thread strength. The stem, bonnet, and male NPT threads are rolled, not cut.
- **Mirror stem finish** burnished to a 16 RMS finish in the packing area enables smooth stem operation and extends packing life.
- **Body-to-bonnet seal** is metal-to-metal in constant compression, isolating the bonnet threads from process fluid corrosion. Eliminates possible tensile breakage of bonnet, and gives a reliable seal point.
- **Bonnet lock pin** is another safety feature which prevents the accidental separation of the bonnet from the body. However, normal valve maintenance and repair are still easily accomplished.
- **Repairable metal seat** can be resurfaced without removing the valve from the line.

## H7 and H71 Specifications<sup>4</sup>

<sup>3</sup>/<sub>16</sub>-inch [4.8 mm]: 6000 and 10,000 psig [414 and 689 barg]

### Dimensions, inches [mm]

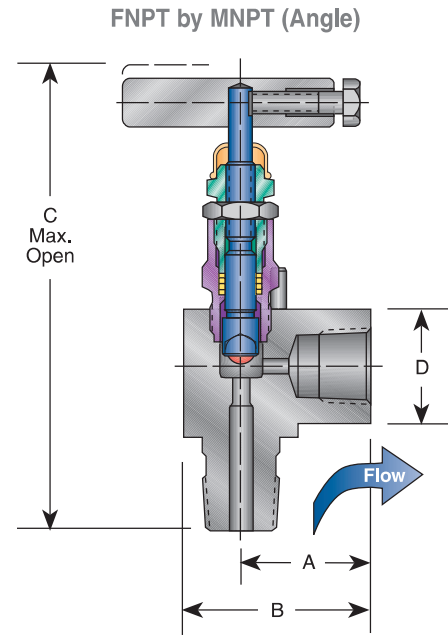
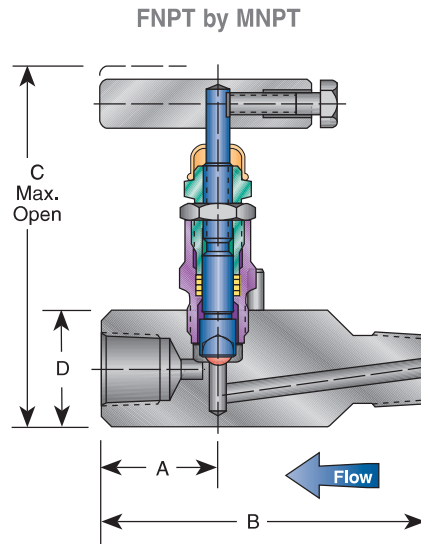
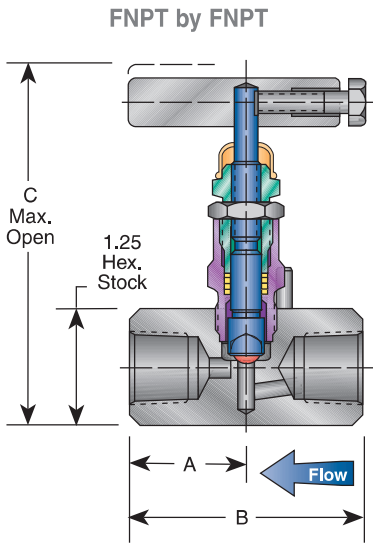

#### FNPT by FNPT

Valve <sup>1</sup>	A	B	C <sup>2</sup> Teflon®	C <sup>2</sup> GRAFOIL®
1/4" F x 1/4" F	1.25 [31.8]	2.50 [63.5]	3.92 [99.6]	4.57 [116.1]
1/2" F x 1/2" F <sup>3</sup>	1.50 [38.1]	3.00 [76.2]	3.92 [99.6]	4.57 [116.1]

#### FNPT by MNPT

Valve <sup>1</sup>	A	B	C <sup>2</sup> Teflon®	C <sup>2</sup> GRAFOIL®	D
1/4" F x 1/2" M	1.25 [31.8]	3.50 [88.9]	3.85 [97.8]	4.50 [114.3]	1.25 [31.8]
1/2" F x 1/2" M	1.25 [31.8]	3.50 [88.9]	3.85 [97.8]	4.50 [114.3]	1.25 [31.8]
3/4" F x 3/4" M	1.50 [38.1]	4.50 [114.3]	4.10 [104.1]	4.75 [120.7]	1.50 [38.1]

#### FNPT by MNPT (Angle)

Valve <sup>1</sup>	A	B	C <sup>2</sup> Teflon®	C <sup>2</sup> GRAFOIL®	D
1/2" F x 1/2" M	1.40 [35.6]	2.03 [51.6]	5.00 [127.0]	5.50 [139.7]	1.75 [44.5]

### Notes

1. Approximate valve weight: 1.5 lb [0.7 kg].
2. Valve C<sub>v</sub> 0.52 maximum.
3. The CS Teflon® packed valve dimension is A-1.25; B-2.50; C-3.92
4. For Hastelloy® and -SG3 call factory for dimensions and weights.

## H7 and H71 Specifications<sup>6</sup>

<sup>3</sup>/<sub>16</sub>-inch [4.8 mm]: 6000 and 10,000 psig [414 and 689 barg]

### Dimensions inches [mm]

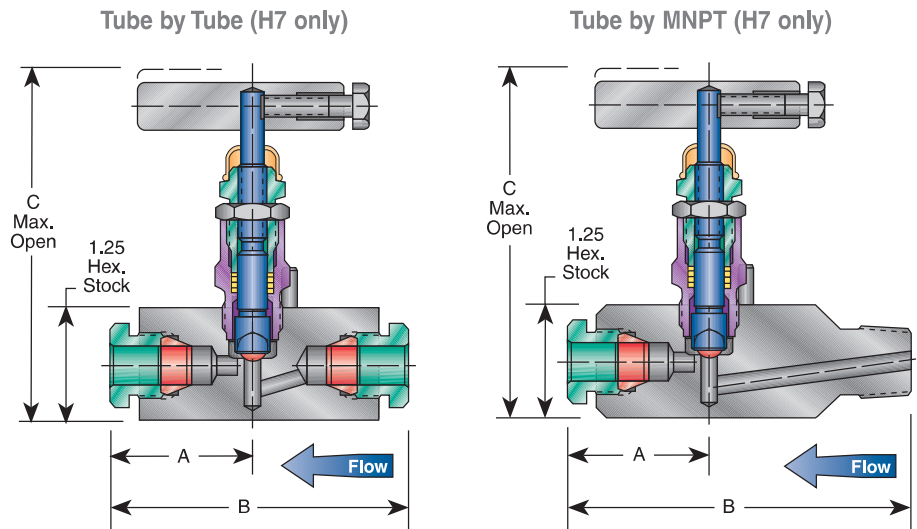

### Notes

1. Approximate valve weight: 1.5 lb [0.7 kg].
2. Valve C<sub>v</sub> 0.52 maximum.
3. H7 only.
4. SG (Sour Gas) meets the requirements of NACE MR0175/ISO 15156-3 Corrigendum 2 (for Chloride conditions ≤ 50 mg/l [ppm]) and NACE MR0103-2005.
5. CS is zinc cobalt plated to prevent corrosion.
6. SG3 (Sour Gas) meets the requirements of NACE MR0175/ISO 15156-3 Corrigendum 2 (for Chloride conditions > 50 mg/l [ppm]).
7. Elgiloy<sup>®</sup> is a registered trademark of Elgiloy Specialty Metals.

### Tube by Tube (H7 only)

Valve <sup>1</sup>	A	B	C <sup>2</sup> Teflon <sup>®</sup>	C <sup>2</sup> GRAFOIL <sup>®</sup>
1/4" T x 1/4" T	1.68 [42.7]	3.16 [80.3]	3.85 [97.8]	4.50 [114.3]
3/8" T x 3/8" T	1.63 [41.4]	3.75 [95.3]	3.85 [97.8]	4.50 [114.3]
1/2" T x 1/2" T	1.88 [47.8]	3.75 [95.3]	3.85 [97.8]	4.50 [114.3]

### Tube by MNPT (H7 only)

Valve <sup>1</sup>	A	B	C <sup>2</sup> Teflon <sup>®</sup>	C <sup>2</sup> GRAFOIL <sup>®</sup>
3/8" T x 1/2" M	1.63 [41.4]	3.88 [98.6]	3.85 [97.8]	4.50 [114.3]
1/2" T x 1/2" M	1.88 [47.8]	4.13 [104.9]	3.85 [97.8]	4.50 [114.3]

### Standard Materials

#### Teflon<sup>®</sup> Packing (H7 and H71)

Valve	Body and Bonnet <sup>5</sup>	Stem	Ball
CS	A108	A581 303	17-4 PH
SS	A479-316	A276-316	316 SS
Monel <sup>®3</sup>	Monel <sup>®</sup> R405	Monel <sup>®</sup> 400	Monel <sup>®</sup> K500
SG <sup>4</sup>	A479-316	Monel <sup>®</sup> 400	Monel <sup>®</sup> K500
SG3 <sup>6</sup>	Hastelloy <sup>®</sup> C-276	Hastelloy <sup>®</sup> C-276	Elgiloy <sup>®</sup>

#### GRAFOIL<sup>®</sup> Packing (H7 Only)

Valve	Body and Bonnet <sup>5</sup>	Stem	Ball
CS	A105	A581 303	17-4 PH
SS	A479-316	A276-316	316 SS
SG <sup>4</sup>	A479-316	Monel <sup>®</sup> 400	Monel <sup>®</sup> K500
SG3 <sup>6</sup>	Hastelloy <sup>®</sup> C-276	Hastelloy <sup>®</sup> C-276	Elgiloy <sup>®</sup>

## H7 and H71 Specifications

<sup>3</sup>/<sub>16</sub>-inch [4.8 mm] Orifice: 6000 and 10,000 psig [414 and 689 barg]

### Pressure vs. Temperature – H7

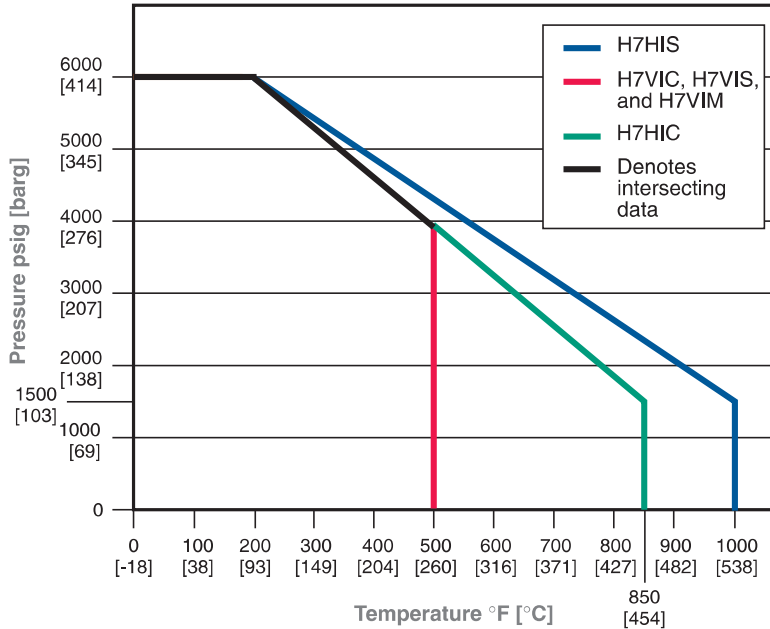

### Pressure and Temperature Ratings

Valve	Teflon® Packed Bonnet	
CS	6000 psig @ 200°F	[414 barg @ 93°C]
	1500 psig @ 850°F	[103 barg @ 454°C]
SS	6000 psig @ 200°F	[414 barg @ 93°C]
	1500 psig @ 1000°F	[103 barg @ 538°C]
Monel®	6000 psig @ 200°F	[414 barg @ 93°C]
	1500 psig @ 850°F	[103 barg @ 454°C]
Hastelloy®	6000 psig @ 200°F	[414 barg @ 93°C]
	1500 psig @ 850°F	[103 barg @ 454°C]

### Valve GRAFOIL® Packed Bonnet and Low Emissions Graphite Packed Bonnet

CS	6000 psig @ 200°F	[414 barg @ 93°C]
	1500 psig @ 850°F	[103 barg @ 454°C]
SS	6000 psig @ 200°F	[414 barg @ 93°C]
	1500 psig @ 1000°F	[103 barg @ 538°C]
Hastelloy®	6000 psig @ 200°F	[414 barg @ 93°C]
	1500 psig @ 850°F	[103 barg @ 454°C]

### Pressure vs. Temperature – H71

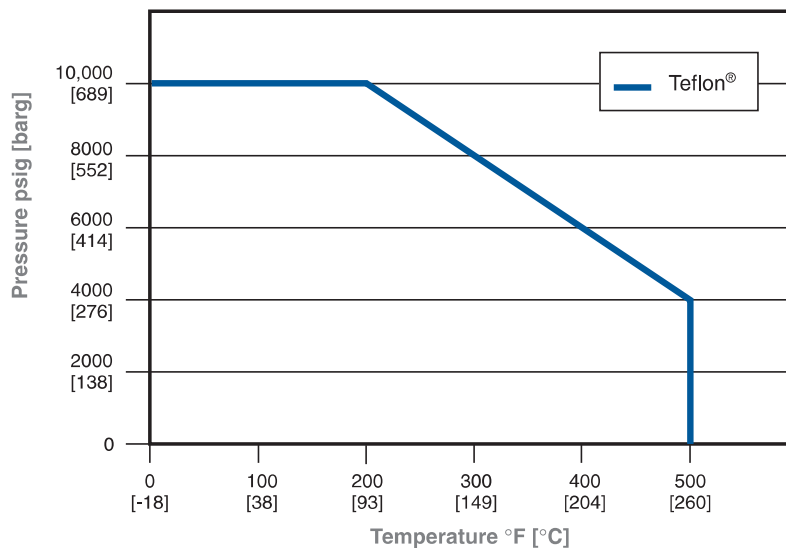

### Pressure and Temperature Ratings

Valve	Teflon® Packed Bonnet	
CS, SS	10,000 psig @ 200°F	[689 barg @ 93°C]
SS, SG3	4000 psig @ 500°F	[276 barg @ 260°C]

## H7 and H71 Options

<sup>3</sup>/<sub>16</sub>-inch [4.8 mm] Orifice: 6000 and 10,000 psig [414 barg]

### AGCO Tube<sup>1</sup>

#### Integral Tube Fitting Design (H7 only)

- Proven design performance
- No tube twist on makeup
- Low torque assembly
- Male nut
  - Silver-plated to prevent galling
  - Threads are rolled for additional strength
  - Gives superior tubing support for vibration resistance
- Bubble-tight seal on make and remakes
- Fitting will hold to the burst of the tubing
- Makeup is industry standard 1<sup>1</sup>/<sub>4</sub> turns from finger tight.
- Remake is 1/4 turn from finger tight which brings you back to original position, then snug slightly to respring the ferrule(s) into a sealing position.

Available with single or dual ferrule design:

#### Single Ferrule Design

Option is ‘-( ) AT’

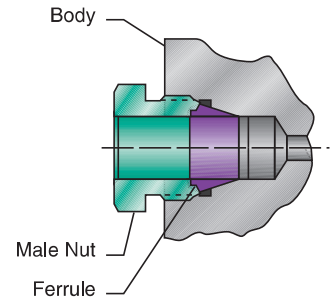

#### Dual Ferrule Design

Option is ‘-( ) ATD’

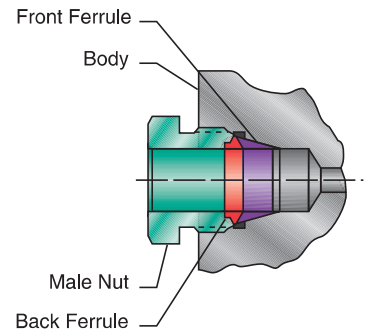

#### Note

1. AGCO Tube option meets the requirements of NACE.

### Bonnet Lock (BL)<sup>1</sup>

The Anderson Greenwood Bonnet Lock prevents accidental loosening of the bonnet-to-body seal. A high-strength, short bonnet pin aligns a hex collar over the bonnet. A standard panel nut locks the collar against the valve. Tests indicate the minimum torque required to break the collar loose is greater than the torque required to twist off handle. Available with GRAFOIL<sup>®</sup> packed bonnets only.

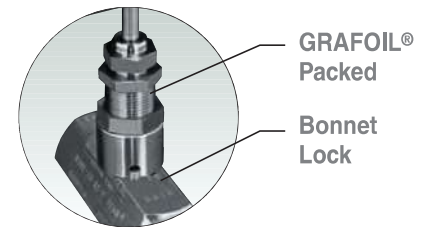

#### Note

1. Patent protected.



## H7 Specifications

<sup>3</sup>/<sub>16</sub>-inch [4.8 mm] Orifice: 6000 psig [414 barg]

### Ordering Information

**H7                      V                      I                      S                      - 44Q                      - SG**

#### Packing

- V - Teflon®
- H - GRAFOIL®
- E - Low Emissions Graphite

#### Seat

- I - Integral

#### Material

- C - CS
- S - 316 SS
- M - Monel®
- J - Hastelloy®

#### Connections (Inlet/Outlet)

- 2        - 1/4-inch FNPT x 1/4-inch FNPT
- 24       - 1/2-inch MNPT x 1/4-inch FNPT
- 4Q       - 1/2-inch FNPT x 1/2-inch FNPT
- 44Q      - 1/2-inch MNPT x 1/2-inch FNPT
- 46Q      - 3/4-inch MNPT x 1/2-inch FNPT
- 44QA    - 1/2-inch MNPT x 1/2-inch FNPT Angle
- 4AT      - 1/2-inch Tube x 1/2-inch Tube
- 66Q      - 3/4-inch MNPT x 3/4-inch FNPT

#### Option/Descriptions

- AL    - Arctic Lubricant (low temperature service -70°F) - not available for CS valves
- BL    - Bonnet Lock (patent protected) (page 21)
- PHB - Phenolic Round Black Handle
- PM    - Panel Mount (GRAFOIL® bonnet only)
- C      - Male Plain End
- SG    - (Sour Gas) meets the requirements of NACE MR0175/ISO 15156-3 Corrigendum 2 (for Chloride conditions ≤ 50 mg/l [ppm]) and NACE MR0103-2005 (316 SS only)
- SG3 - (Sour Gas) meets the requirements of NACE MR0175/ISO 15156-3 Corrigendum 2 (for Chloride conditions > 50 mg/l [ppm])
- SP    - Special Requirements - please specify

## H71 Specifications

<sup>3</sup>/<sub>16</sub>-inch [4.8 mm] Orifice: 10,000 psig [689 barg]

### Ordering Information

	H71	V	I	S	- 44Q	- SG
<b>Packing</b>						
V - Teflon®						
<b>Seat</b>						
I - Integral						
<b>Material</b>						
C - CS						
S - 316 SS						
J - Hastelloy®						
<b>Connections (Inlet/Outlet)</b>						
2 - 1/4-inch FNPT x 1/4-inch FNPT						
24 - 1/2-inch MNPT x 1/4-inch FNPT						
4Q - 1/2-inch FNPT x 1/2-inch FNPT						
44Q - 1/2-inch MNPT x 1/2-inch FNPT						
46Q - 3/4-inch MNPT x 1/2-inch FNPT						
44QA - 1/2-inch MNPT x 1/2-inch FNPT Angle						

### Option/Descriptions

- AL - Arctic Lubricant (low temperature service -70°F) - not available for CS valves
- BL - Bonnet Lock (patent protected) (page 21)
- PHB - Phenolic Round Black Handle
- SG - (Sour Gas) meets the requirements of NACE MR0175/ISO 15156-3 Corrigendum 2 (for Chloride conditions ≤ 50 mg/l [ppm]) and NACE MR0103-2005 (316 SS only)
- SG3 - (Sour Gas) meets the requirements of NACE MR0175/ISO 15156-3 Corrigendum 2 (for Chloride conditions > 50 mg/l [ppm])
- SP - Special Requirements - please specify

## Hard Seated Valves – H7 ASME B31.1 or B31.3

3/16-inch [4.8 mm] ASME B31.1 or B31.3 – Meets MSS-SP-105

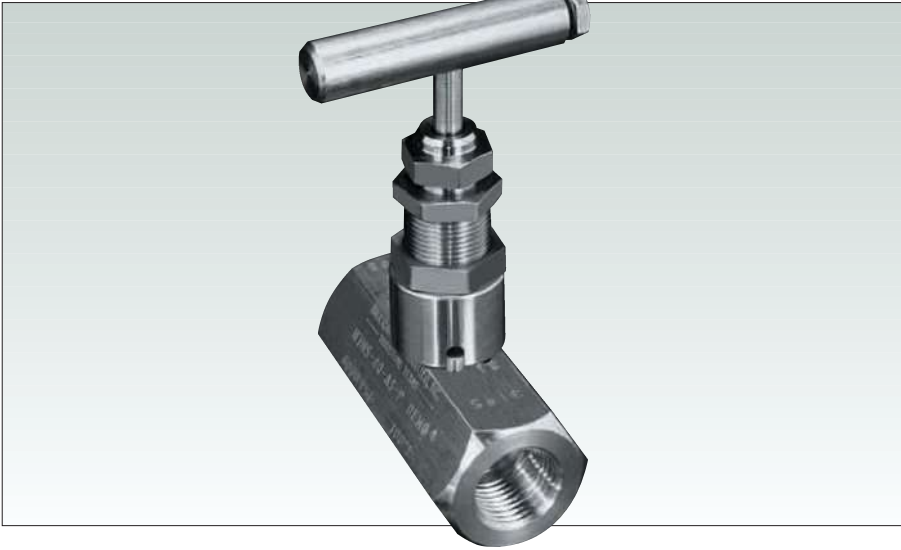

Globe pattern instrument hand valve used in severe service isolation, drain and test applications.

### Features and Benefits

- **Stem packing** is GRAFOIL® standard for high-temperature service.
- **Free-swiveling SS ball stem** prevents seating surface damage and ensures perfect alignment cycle after cycle. The differential hardness between the ball and seat assures bubble-tight shutoff.
- **One-piece handle assembly** prevents loss due to vibration or maintenance. If handle is removed, locking bolt remains with handle.
- **Rolled stem threads** prevent galling and extend valve life. Stem is polished to a mirror finish to minimize packing wear.
- **Back Seat design** provides secondary stem seal and prevents accidental stem blowout under pressure.
- **Full pressure and temperature range** up to ASME Class 2500.
- **Bonnet lock (patented)** prevents accidental loosening of the bonnet-to-body seal. A high-strength short bonnet pin aligns a hex collar over the bonnet. A standard panel nut then locks the collar against the valve body. The nut allows all instrument valves to be panel-mounted without any additional parts. Tests indicate that the minimum torque required to break the collar loose is greater than the torque required to twist off the valve handle.
- **Bonnet-to-body, metal-to-metal seal point** places the seal in constant compression below the bonnet threads. This prevents bonnet thread corrosion, eliminates possible tensile breakage of the bonnet, and provides a reliable seal point.
- **Repairable metal seat** can be resurfaced without removing the valve from the line.
- **Code materials of construction** are designed to meet requirements of ASME B31.1 or ASME B31.3.
- **Optional end connections**
  - Pipe Socket Weld
  - AGCO Tube
  - Tube Socket Weld
  - Tube Stub
  - FNPT

## Hard Seated Valves – H7 ASME B31.1 or B31.3

<sup>3</sup>/<sub>16</sub>-inch [4.8 mm] ASME B31.1 or B31.3 – Meets MSS-SP-105

### ASME B31.1 or B31.3

Valve design criteria is described in Section 107. Important considerations from this section are as follows:

1. Valves require specific pressure and temperature ratings such as those found in ASME B16.34.
2. Material requirements must conform to listed ASTM specifications.
3. As a minimum, the valve body should be marked or tagged in accordance with specification MSS-SP-25.
4. Valve design may include screwed, union, or OS&Y bonnets.

The requirements for instrument, control, and sampling systems are found in Section 122. Instrument piping, as defined by this section, includes that piping from the instrument root valve (or first valve off the main piping line) up to but not including the instrument, transmitter, or any other measuring and sensing device.

The instrument valve or manifold must be designed to withstand full system design pressure at the design temperature or the corresponding saturation temperature if the service is steam. Even though the instrument will never be subjected to the

system temperature, manifold design requires this protection in the event that the root valve should fail under operating conditions. If blowdown valves are used between the root valve and the manifold, then the manifold design temperature rating need only be 100°F [38°C]. However, in such cases, the pressure rating must be the lesser of 1.5 times the mainline design pressure or the rating of the blowdown valve. The utilization of commercial grade manifolds (without the manufacturer's certification to ASME B31.1 or B31.3 or if stamped WOG) which meet only the pressure ratings are prohibited unless all other code requirements have been met (such as Table 126.1 in ASME B31.1 or B31.3 for materials, compliance to testing requirements, etc).

The final section of the Code, Section I, 137, specifies the criteria for testing. All instrument manifold valves are required to be hydrostatically tested by the manufacturer to certify compliance with the Code. Hydrostatic testing is performed, as a minimum, in accordance with MSS-SP-61. This testing includes the body cavity hydrostatic test at 1.5 times the design pressure rating and seat leakage test(s) at 1.1 times the maximum pressure rating.

### Pressure and Temperature Ratings

Body Material	Pressure and Temperature Ratings			
SS, A479-316	6000 psig @	100°F	[414 barg @	38°C]
	2915 psig @	1000°F	[201 barg @	538°C]
CS, A105	6170 psig @	100°F	[426 barg @	38°C]
	3430 psig @	800°F	[237 barg @	426°C]
Hastelloy®	6170 psig @	100°F	[426 barg @	38°C]
	3430 psig @	800°F	[237 barg @	426°C]

### Notes

1. All B31.1 or B31.3 products are ASME Class 2500.
2. Approximate valve weight: 1.3 lb [0.6 kg].  
Orifice Size 0.187-inch [4.8 mm].  
Valve C<sub>v</sub> 0.52 maximum.

## Hard Seated Valves – H7 ASME B31.1 or B31.3

3/16-inch [4.8 mm] ASME B31.1 or B31.3

### Ordering Information - Power Industry Applications<sup>1</sup>

**H7HP S – 4Q – XP – SP**

#### Body Material

- C – CS, A105
- S – SS, A479-316
- J – Hastelloy®

#### Connections (Inlet/Outlet)

2	–	1/4-inch FNPT	x	1/4-inch FNPT
2B	–	1/4-inch Pipe S.W.	x	1/4-inch Pipe S.W. <sup>2</sup>
3	–	3/8-inch FNPT	x	3/8-inch FNPT
3TB	–	3/8-inch Tube S.W.	x	3/8-inch Tube S.W. <sup>2,3</sup>
3TC	–	3/8-inch Tube Stub	x	3/8-inch FNPT <sup>2,4</sup>
3B	–	3/8-inch Pipe S.W.	x	3/8-inch Pipe S.W.
4Q	–	1/2-inch FNPT	x	1/2-inch FNPT
4QB	–	1/2-inch Pipe S.W.	x	1/2-inch Pipe S.W.
4AT	–	1/2-inch AGCO Tube	x	1/2-inch AGCO Tube <sup>2,6</sup>
4TB	–	1/2-inch Tube S.W.	x	1/2-inch Tube S.W. <sup>2,3</sup>
4TC	–	1/2-inch Tube Stub	x	1/2-inch Tube Stub <sup>2,5</sup>
44Q	–	1/2-inch MNPT	x	1/2-inch FNPT
4QB4	–	1/2-inch Pipe S.W.	x	1/2-inch FNPT <sup>2</sup>
46Q	–	3/4-inch MNPT	x	1/2-inch FNPT
6Q	–	3/4-inch FNPT	x	3/4-inch FNPT <sup>2</sup>
6TB	–	3/4-inch Tube S.W.	x	3/4-inch Tube S.W. <sup>2,3</sup>
6QB	–	3/4-inch Pipe S.W.	x	3/4-inch Pipe S.W. <sup>2</sup>

#### Options

SP – Special Requirements - please specify

#### Notes

1. All H7 ASME B31.1 or B31.3 valves come standard with GRAFOIL® packing, integral seats, bonnet locks, and are subjected to hydrostatic testing.
2. Only available with the 'S' body material option.
3. Available in O.D. tube sizes only.
4. Tube Stubs (both ends) are 6-inches long x 0.065-inch wall [152 mm long x 1.65 mm wall] (ASME 2500 Class).
5. Tube Stubs (both ends) are 6-inches long x 0.095-inch wall [152 mm long x 2.41 mm wall] (ASME 2500 Class).
6. Single Ferrule is standard. For Double Ferrule add 'D' (i.e. H7HPS - '4ATD').

## Hand Valves – HM25H

Globe Pattern, <sup>5</sup>/<sub>16</sub>-inch [8 mm] bore, 6000 psig [414 barg]

### Product Overview

The HM25H (6000 psig [414 barg]) barstock valve features a large, <sup>5</sup>/<sub>16</sub>-inch [8 mm] globe pattern bore, allowing free passage of viscous processes. The ball stem end provides repetitive, bubble-tight shutoff.

The HM25H is available in a wide variety of inlet and outlet configurations and materials, including either Teflon® or GRAFOIL® packing, or an O-ring seal.



### Features and Benefits

- **The ball end provides** bubble-tight shutoff and ensures long valve life. The non-rotating ball stem end also eliminates seat galling.
- **Overly large handle** ensures ease of operation while actuating valve.
- **All valves are pressure tested** prior to factory shipment. Material traceability on body is standard on each HM25H if requested.
- **Both the Teflon® and GRAFOIL® packings** are easily adjustable in the field.
- **All packing is below the threads**, which ensures the process does not contaminate the valve's actuation threads. This feature ensures smooth valve operation and long service life.
- **All HM25H's feature safety back seating**, ensuring the prevention of both accidental stem blowout and removal under pressure.
- **An upgraded bonnet lock-plate** is featured for all HM25H's in the severe service series to prevent accidental removal of bonnet assembly under pressure.
- **Standard dust covers ensure long service life** by preventing the elements (rain, snow, dirt, etc.) access to the bonnet assembly.

## HM25H Specifications

Globe Pattern, 5/16-inch [8 mm] bore, 6000 psig [414 barg]

### Pressure vs. Temperature

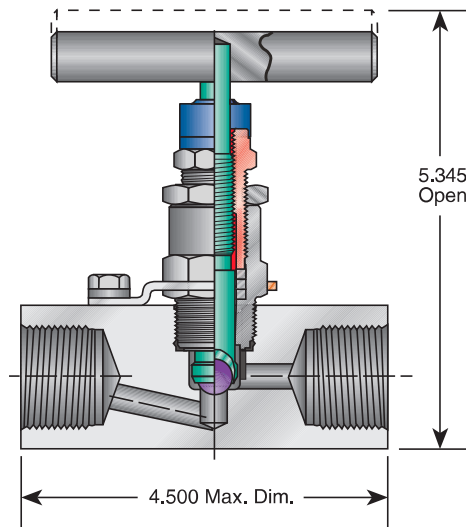
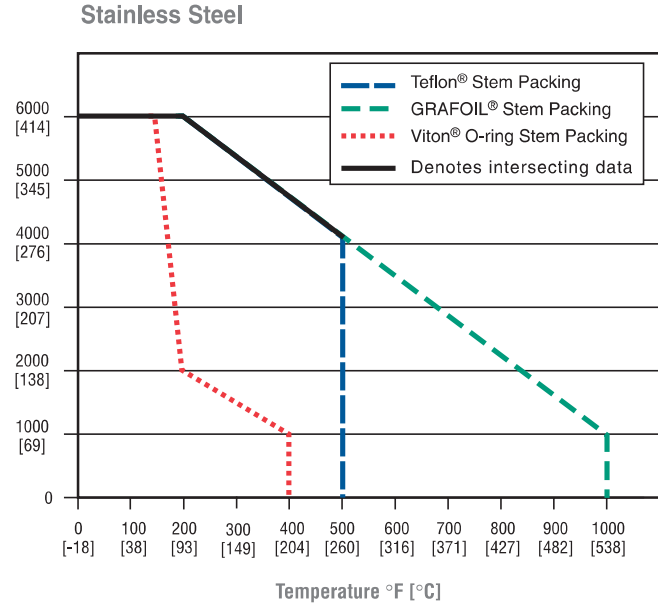
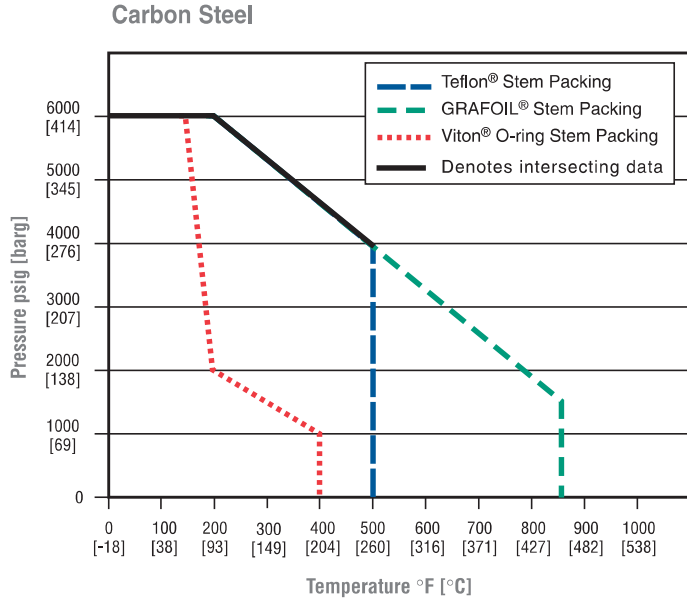

## HM25H Specifications

Globe Pattern, 5/16-inch [8 mm] bore, 6000 psig [414 barg]

### Ordering Information

	HM25H	S	4	G	H	SCL	SP
<b>Material<sup>1</sup></b>							
	C – CS						
	S – 316 SS, 316L SS						
<b>Connections (Inlet/Outlet)</b>							
	4 – 1/2-inch FNPT x 1/4-inch FNPT						
	44 – 1/2-inch MNPT x 1/2-inch FNPT						
	46 – 3/4-inch MNPT x 1/2-inch FNPT						
	6 – 3/4-inch FNPT x 3/4-inch FNPT						
	66 – 3/4-inch MNPT x 3/4-inch FNPT						
	8 – 1-inch FNPT x 1-inch FNPT						
	88 – 1-inch MNPT x 1-inch FNPT						
<b>Stem</b>							
	G – Non-rotating Ball Stem End						
<b>Packing</b>							
	V – Teflon®						
	H – GRAFOIL®						
	R – Viton® O-ring						
<b>Bonnet Lock Plate</b>							
	SCL – Bonnet Lock Plate Upgrade (ASME B31.1 or B31.3)						
<b>Option/Descriptions</b>							
	AL – Arctic Lubricant (low temperature service -70°F) - not available for CS valves						
	LB – Lockable Bonnet (consult factory)						
	OC – Gaseous Oxygen Cleaned						
	SP – Special Requirements - please specify						

### Notes

1. Call factory for optional materials.
2. All seats on the HM25D Series are integral.  
No ordering code required.



## Hand Valves – HM25D

Globe Pattern, 7/16-inch [11 mm] bore, 6000 psig [414 barg]



### Product Overview

The HM25D (6000 psig [414 barg]) barstock construction globe pattern hand valve features a  $C_v$  rating of 1.95, and is ideally suited for severe service, high-temperature applications. The globe pattern construction of this unit ensures reliable bubble-tight shutoff for the most severe of services.

The standard packing for the HM25D is GRAFOIL® for high-temperature compatibility; however, Teflon® is readily available.

The HM25D is available in a wide variety of inlet and outlet configurations and materials, as well.

### Features and Benefits

- **Non-rotating ball stem tip** provides reliable bubble-tight shutoff of large, 7/16-inch [11 mm], globe pattern bore.
- **Overly large handle** ensures ease of operation while actuating valve.
- **All valves are pressure tested** prior to factory shipment. Material traceability on body is standard on each HM25H if requested.
- **Both the Teflon® and GRAFOIL® packings** are easily adjustable in the field.
- **All packing is below the threads**, which ensures the process does not contaminate the valve's actuation threads. This feature ensures smooth valve operation and long service life.
- **All HM25D's feature safety back seating**, ensuring the prevention of both accidental stem blowout and removal under pressure.
- **An upgraded bonnet lock-plate** is featured for all HM25H's in the severe service series to prevent accidental removal of bonnet assembly under pressure.

## HM25D Specifications

Globe Pattern, 7/16-inch [11 mm] bore, 6000 psig [414 barg]

### Pressure vs. Temperature

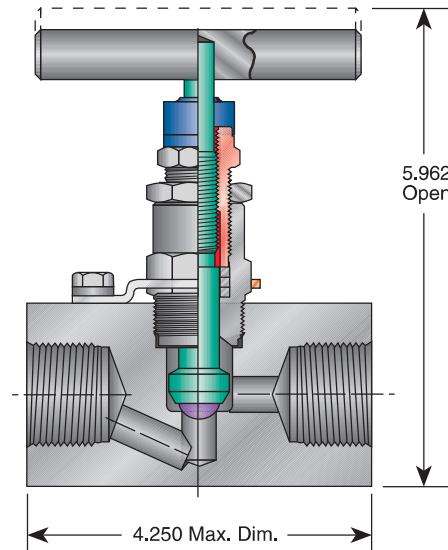
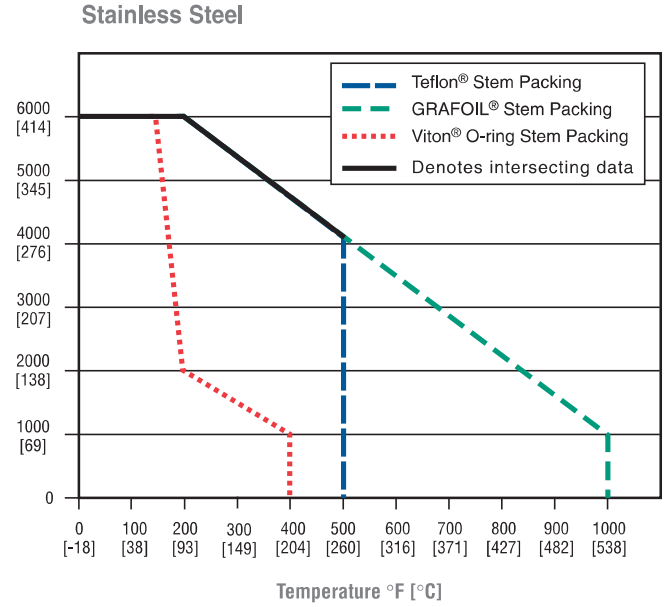
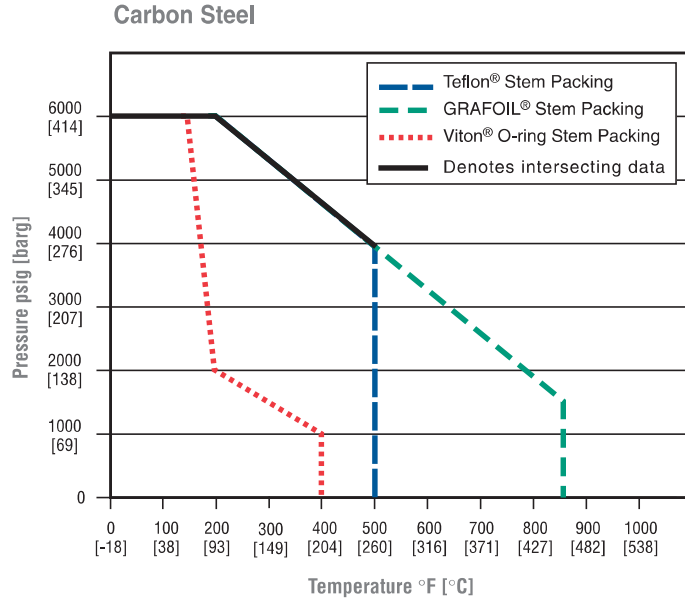

## HM25D Specifications

Globe Pattern, 7/16-inch [11 mm] bore, 6000 psig [414 barg]

### Ordering Information

	HM25D	S	8	G	H	SCL	SP
<b>Material<sup>1</sup></b>							
C - CS							
S - 316 SS, 316L SS							
<b>Connections (Inlet/Outlet)</b>							
6 - 3/4-inch FNPT x 3/4-inch FNPT							
66 - 3/4-inch MNPT x 3/4-inch FNPT							
8 - 1-inch FNPT x 1-inch FNPT							
88 - 1-inch FNPT x 1-inch MNPT							
<b>Stem</b>							
G - Non-rotating Ball Stem End							
<b>Packing</b>							
V - Teflon®							
H - GRAFOIL®							
<b>Bonnet Lock Plate</b>							
SCL - Bonnet Lock Plate Upgrade							
<b>Option/Descriptions</b>							
AL - Arctic Lubricant (low temperature service -70°F) - not available for CS valves							
LB - Lockable Bonnet (consult factory)							
OC - Gaseous Oxygen Cleaned							
SP - Special Requirements - please specify							

### Notes

1. Call factory for optional materials.
2. All seats on the HM25D Series are integral.  
No ordering code required.

## Hand Valves – HM1C

Straight-through (Roddable), Soft Seat, 5/8-inch [16 mm] bore, 3000 psig [207 barg]

### Product Overview

The HM1C (3000 psig [207 barg]) barstock construction valve is a severe service, high-pressure/temperature, straight-through (roddable) bi-directional flow unit. The HM1C features a  $C_v$  rating of 9.8 which allows for high flow capacities. The HM1C is also ideally suited for process conditions where potential plugging is a concern.

It features a replaceable soft seat, which can be easily removed and replaced, eliminating the need for valve removal should the seat become damaged by process conditions.

The HM1C is available in a wide variety of inlet and outlet configurations and materials. The HM1C is available with either Teflon® or GRAFOIL® packing.



### Features and Benefits

- **Plug stem end** provides bubble-tight shutoff and ensures long valve life. Replaceable/repairable seat ensures long, safe and economically installed valve life.
- **Upgraded large handle** ensures ease of operation while actuating valve.
- **All valves are pressure tested** prior to factory shipment. Material traceability on body is standard on each HM25H if requested.
- **The Teflon® packing** is easily adjustable in the field.
- **All packing is below the threads**, which ensures the process does not contaminate the valve's actuation threads. This feature ensures smooth valve operation and long service life.
- **All HM1C's feature safety back seating**, ensuring the prevention of both accidental stem blowout and removal under pressure.
- **All HM1C's in the severe service series** feature an upgraded bonnet lock plate to ensure accidental removal under pressure does not occur.
- **Standard dust covers** ensure long service life by preventing the elements (rain, snow, dirt, etc.) access to the bonnet assembly.

## HM1C Specifications

Straight-through (Roddable), Soft Seat, 5/8-inch [16 mm] bore, 3000 psig [207 barg]

### Ordering Information

**HM1C S 8 GN S V SCL SP**

#### Material<sup>1</sup>

- C - CS
- S - 316 SS, 316L SS

#### Connections (Inlet/Outlet)

- 4 - 1/2-inch FNPT x 1/4-inch FNPT
- 44 - 1/2-inch MNPT x 1/2-inch FNPT
- 46 - 3/4-inch MNPT x 1/2-inch FNPT
- 6 - 3/4-inch FNPT x 3/4-inch FNPT
- 66 - 3/4-inch MNPT x 3/4-inch FNPT
- 8 - 1-inch FNPT x 1-inch FNPT
- 88 - 1-inch MNPT x 1-inch FNPT

#### Stem

- GN - Plug Stem End

#### Seat

- S - 316 SS
- D - Delrin®
- K - PEEK

#### Packing

- V - Teflon®
- R - Viton® O-ring

#### Bonnet Lock Plate

- SCL - Bonnet Lock Plate Upgrade

#### Option/Descriptions

- AL - Arctic Lubricant (low temperature service -70°F) - not available for CS valves
- OC - Gaseous Oxygen Cleaned
- SP - Special Requirements - please specify

#### Note

1. Call factory for optional materials.

### Pressure vs. Temperature

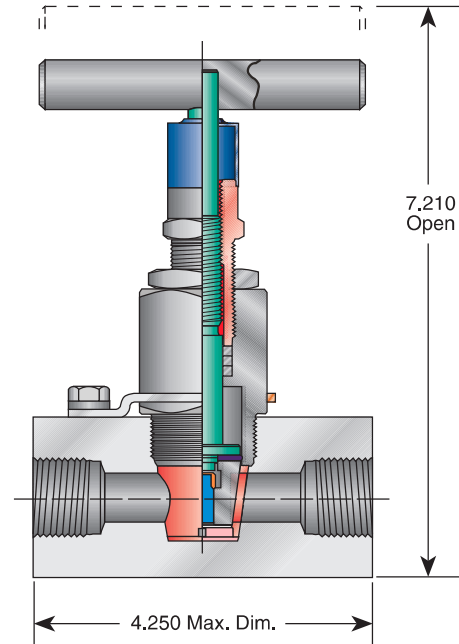
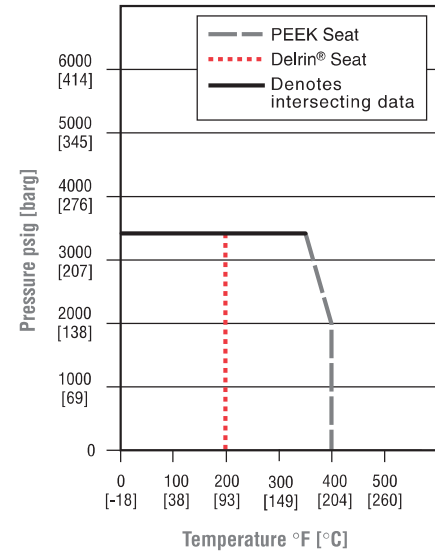

## Mini Valves – H5

6000 psig [414 barg]

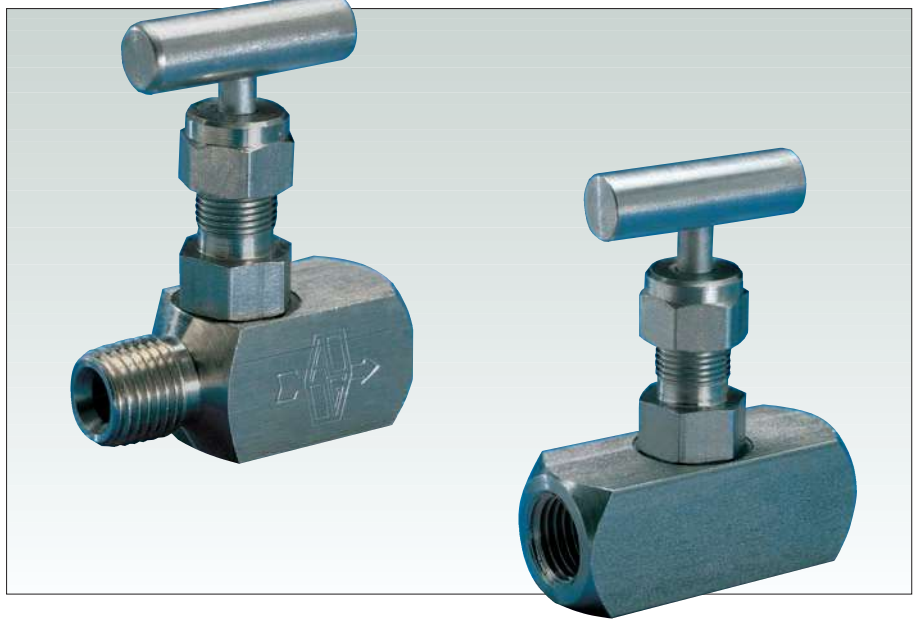

### Product Overview

The H5 Mini Valves facilitate safe, compact, and economical installations. They are excellent for straight isolation.

Valve seating is interchangeable between 'Hard' or 'Soft' without changing the bonnet assembly or removing valve from the installation. This feature of the H5 greatly extends the valve life.

### Features and Benefits

- **Packing below threads (O-ring bonnet)** prevents lubricant washout, thread corrosion, and keeps solids from entering thread area, which can cause galling. It also prevents process contamination.
- **Adjustable packing** – Teflon® and GRAFOIL® packed bonnets adjust easily, decreasing packing replacement downtime and increasing valve life.
- **Safety back seating** prevents stem blowout or accidental removal while in operation and provides a metal-to-metal secondary stem seal while in the full open position.

- **Chrome plating of 316 SS stem** prevents galling or freezing of stem threads when similar metals mate. CS valves use a 303 SS stem.
- **Rolled threads** provide additional thread strength. The stem, bonnet, and male NPT threads are rolled, not cut.
- **Mirror stem finish** burnished to a 16 RMS finish in the packing area enables smooth stem operation and extending packing life.
- **One-piece handle design** prevents loss of the valve handle due to vibration or during maintenance.
- **Soft or metal seat for bubble-tight shutoff** is field replaceable for easy maintenance.
- **Extended valve life** – if soft seat becomes damaged it can be removed, leaving a metal seated valve.

## H5 Specifications<sup>3</sup>

6000 psig [414 barg]

### Dimensions, inches [mm]

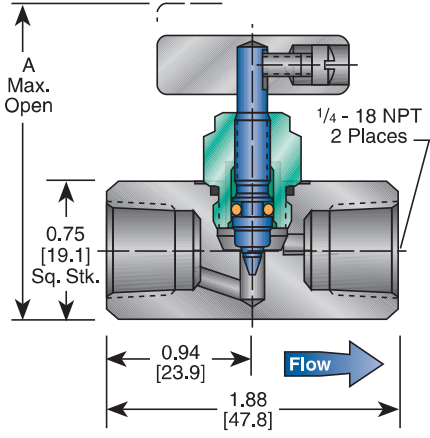

Maximum Open – Dimension A

O-ring	Teflon®	GRAFOIL®
2.00 [50.8]	2.60 [66.0]	3.07 [78.0]

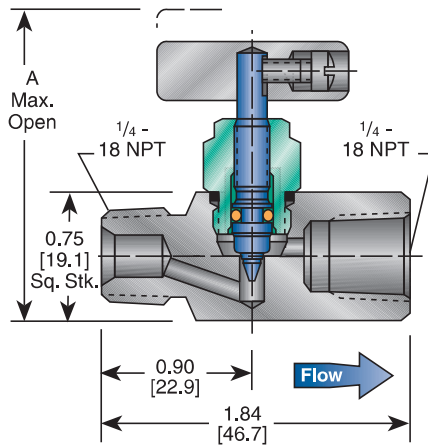

Maximum Open – Dimension A

O-ring	Teflon®	GRAFOIL®
2.00 [50.8]	2.60 [66.0]	3.07 [78.0]

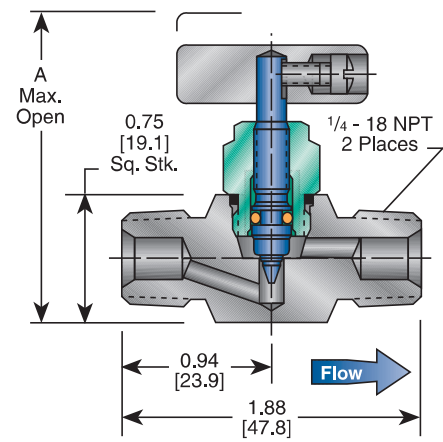

Maximum Open – Dimension A

O-ring	Teflon®	GRAFOIL®
2.00 [50.8]	2.60 [66.0]	3.07 [78.0]

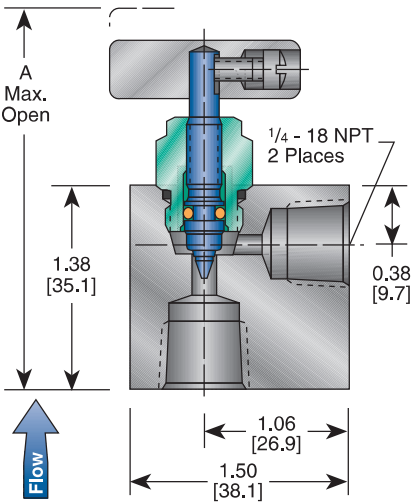

Maximum Open – Dimension A

O-ring	Teflon®	GRAFOIL®
2.64 [67.1]	3.23 [82.0]	3.71 [94.2]

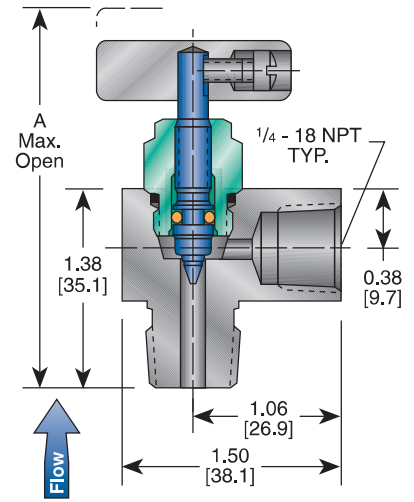

Maximum Open – Dimension A

O-ring	Teflon®	GRAFOIL®
2.66 [67.6]	3.26 [82.8]	3.73 [94.7]

### Notes

1. Approximate valve weight: 0.5 lb [23 kg]. Seat orifice size 0.136-inch [3.5 mm] diameter.
2. Valve C<sub>v</sub> Soft Seat 0.27 maximum. Valve C<sub>v</sub> Hard Seat 0.31 maximum.
3. For Hastelloy® and -SG3 call factory for dimensions and weights.

## H5 Specifications

6000 psig [414 barg]

### Standard Materials – Hard Seat

Valve	Body	Bonnet	Stem	Packing	Seat	Handle <sup>2</sup>
CS <sup>1</sup>	A108	A108	A581-303	Teflon® or BUNA-N O-ring	Integral	Round
SS	A479-316	A479-316	A276-316	Teflon®, Viton® or GRAFOIL® O-ring	Integral	Tee
Brass	B16	B16	A581-303	Teflon® or BUNA-N O-ring	Integral	Round
SG <sup>3</sup>	A479-316	A479-316	Monel® R405	Teflon® or Viton® O-ring	Integral	Tee
SG <sup>36</sup>	Hastelloy® C-276	Hastelloy® C-276	Hastelloy® C-276	Teflon® or Viton® O-ring	Integral	Tee

### Standard Materials – Soft Seat

Valve	Body	Bonnet	Stem	Packing	Flow Washer	Seat	Handle <sup>2</sup>
CS <sup>1</sup>	A108	A108	A581-303	Teflon® or BUNA-N O-ring	A479-316	Delrin® <sup>4</sup>	Round
SS	A479-316	A479-316	A276-316	Teflon® or Viton® O-ring	A479-316	PCTFE <sup>5</sup>	Tee
Brass	B16	B16	A581-303	Teflon® or BUNA-N O-ring	A479-316	Delrin® <sup>4</sup>	Round
SG <sup>3</sup>	A479-316	A479-316	Monel® R405	Teflon® or Viton® O-ring	A479-316	PCTFE <sup>5</sup>	Tee
SG <sup>36</sup>	Hastelloy® C-276	Hastelloy® C-276	Hastelloy® C-276	Teflon® or Viton® O-ring	Hastelloy® C-276	PCTFE <sup>5</sup>	Tee

### Notes

- CS is zinc cobalt plated to prevent corrosion.
- Tee handle is SS; Round handle is CS.
- SG (Sour Gas) meets the requirements of NACE MR0175/ISO 15156-3 Corrigendum 2 (for Chloride conditions ≤ 50 mg/l [ppm]) and NACE MR0103-2005.
- PEEK available.
- PCTFE (Polychlorotrifluoroethylene) is the exact equivalent of Kel-F®.
- SG3 (Sour Gas) meets the requirements of NACE MR0175/ISO 15156-3 Corrigendum 2 (for Chloride conditions > 50 mg/l [ppm]).

### H5 Metal and Soft Seated Flow Characteristics

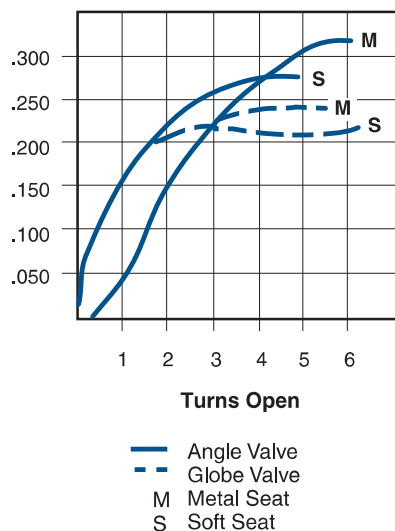

### Formula

### Liquids

$$C_V = Q_L \sqrt{\frac{(P_1 - P_2) (62.4)}{r}}$$

Where:

$Q_L$  = Flow (gpm)

$\rho$  = Density of Liquid (lb/ft<sup>3</sup>)

$P_1$  = Upstream Pressure (psia)

$P_2$  = Downstream Pressure (psia)

$\rho$  (water) = 62.4 lb/ft<sup>3</sup> @ 60°F [16°C]



## H5 Specifications

6000 psig [414 barg]

### Pressure vs. Temperature – CS and SS Valves

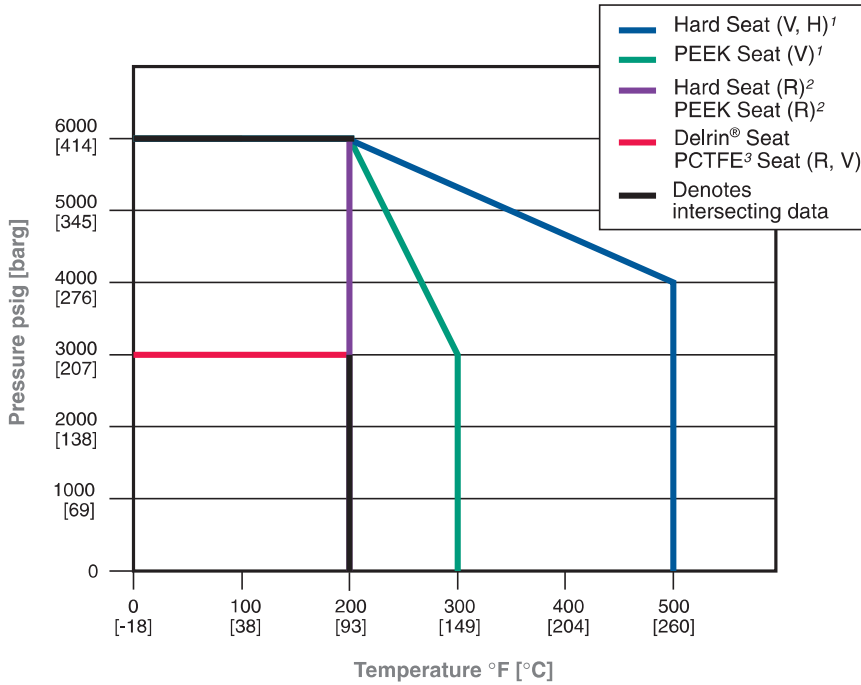

### Notes

1. (V or H) = with Teflon® or GRAFOIL® bonnet assemblies.
2. (R) = with O-ring bonnet assembly.
3. PCTFE (Polychlorotrifluoroethylene) is the exact equivalent of Kel-F®.

### Pressure vs. Temperature – Brass Valves

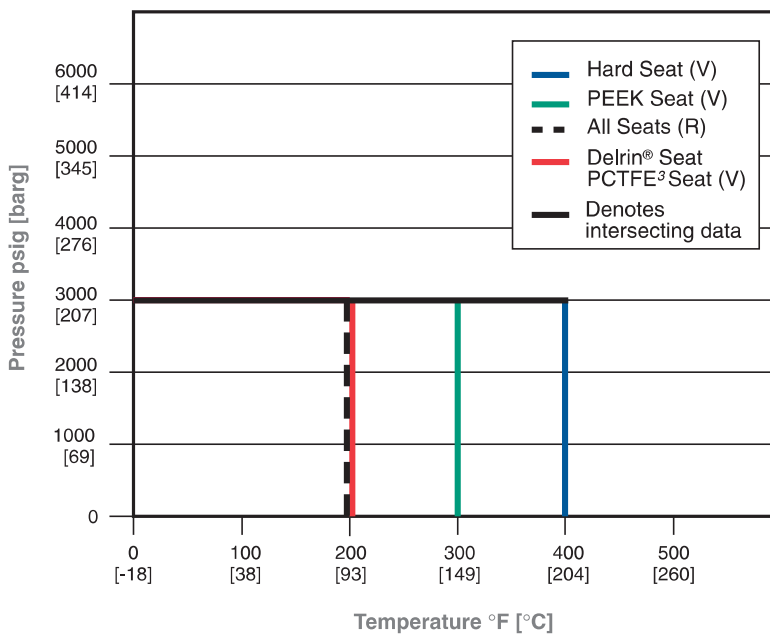

## H5 Specifications

6000 psig [414 barg]

### Pressure and Temperature Ratings<sup>1</sup>

Seat	Teflon® or GRAFOIL® Bonnet <sup>2</sup>			
	CS and SS Valves		Brass Valves	
Hard	6000 psig @ 200°F 4000 psig @ 500°F	[414 barg @ 93°C] [276 barg @ 260°C]	3000 psig @ 400°F	[207 barg @ 204°C]
Delrin® and PCTFE <sup>3</sup>	3000 psig @ 200°F	[207 barg @ 93°C]	3000 psig @ 200°F	[207 barg @ 93°C]
PEEK	6000 psig @ 200°F 3000 psig @ 300°F	[414 barg @ 93°C] [207 barg @ 149°C]	3000 psig @ 300°F	[207 barg @ 149°C]

Seat	O-ring Bonnet			
	CS and SS Valves		Brass Valves	
Hard	6000 psig @ 200°F	[414 barg @ 93°C]	3000 psig @ 200°F	[207 barg @ 93°C]
Delrin® and PCTFE <sup>3</sup>	3000 psig @ 200°F	[207 barg @ 93°C]	3000 psig @ 200°F	[207 barg @ 93°C]
PEEK	6000 psig @ 200°F	[414 barg @ 93°C]	3000 psig @ 200°F	[207 barg @ 93°C]

### Notes

1. Pressure and temperature ratings are not shown on valve body.
2. GRAFOIL® packed bonnet comes complete with ball end stem; SS only.
3. PCTFE (Polychlorotrifluoroethylene) is the exact equivalent of Kel-F®.

## H5 Options<sup>3</sup>

### Optional Panel Mounting Nut<sup>1</sup>, inches [mm]

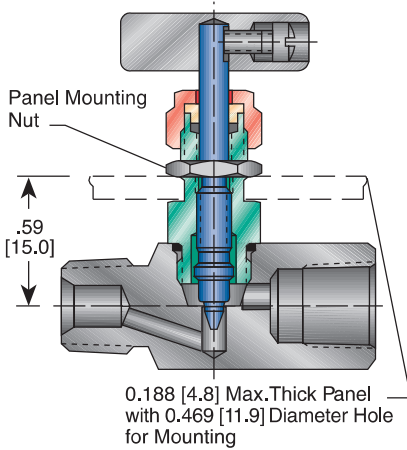

### Optional Soft Seat<sup>2</sup>

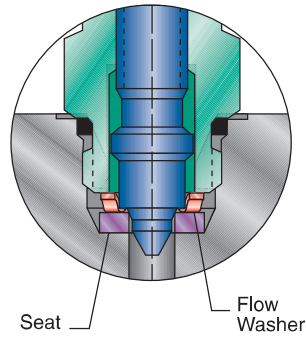

### Optional Phenolic Handles<sup>2</sup>

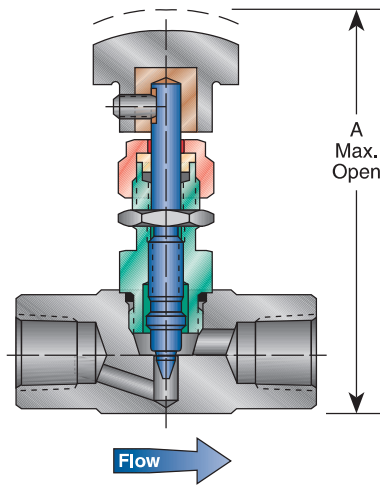

Phenolic Handles are available in 1-inch [25 mm] diameter. Colors available are green, red, and black.

Phenolic Handles facilitate repeatable flow control, as well as enhance the appearance of panels, sample cylinders, and other associated products requiring premium performance throttling and/or isolation valves.

Maximum open dimension of any H5 with Phenolic Handles is calculated by adding 0.4-inch [10.2 mm] to the 'A' reference dimension for Teflon<sup>®</sup> Stem Seal on page 36.

### Notes

1. Available with Teflon<sup>®</sup> packed bonnet.
2. Available on all H5 products.
3. For Hastelloy<sup>®</sup> and -SG3 call factory for dimensions and weights.

## H5 Specifications

### Ordering Information

	H5	V	D	S	- 22	- SG
<b>Packing</b>						
V - Teflon® (standard for SS)						
R - O-ring						
H - GRAFOIL® (SS only) 500°F [260°C] max						
<b>Seat</b>						
I - Integral						
D - Delrin®						
E - PEEK						
K - PCTFE <sup>1</sup> (standard for SS)						
<b>Material</b>						
B - Brass						
C - CS						
S - SS						
J - Hastelloy						
<b>Connections (Inlet/Outlet)</b>						
2 - 1/4-inch F x 1/4-inch F						
2A - 1/4-inch F x 1/4-inch F (Angle)						
2M - 1/4-inch M x 1/4-inch M						
22 - 1/4-inch M x 1/4-inch F						
22A - 1/4-inch M x 1/4-inch F (Angle)						
<b>Options</b>						
CLC - Chlorine Cleaning						
AL - Arctic Lubricant (low temperature service -70°F) - not available for CS valves						
HD - Hydrostatic Testing (100%) (MSS-SP-61)						
MS - Monel® Stem						
OC - Oxygen Cleaning						
PHB - Phenolic Black Handle (page 40)						
PHG - Phenolic Green Handle (page 40)						
PHR - Phenolic Red Handle (page 40)						
PM - Panel Mount (Teflon® packed only) (page 40)						
SG - (Sour Gas) meets the requirements of NACE MR0175/ISO 15156-3 Corrigendum 2 (for Chloride conditions ≤ 50 mg/l [ppm]) and NACE MR0103-2005						
SG3 - (Sour Gas) meets the requirements of NACE MR0175/ISO 15156-3 Corrigendum 2 (for Chloride conditions > 50 mg/l [ppm])						
SP - Special Requirement - please specify						

### Note

1. PCTFE (Polychlorotrifluoroethylene) is the exact equivalent of Kel-F®.

## Gauge Siphon – CT7

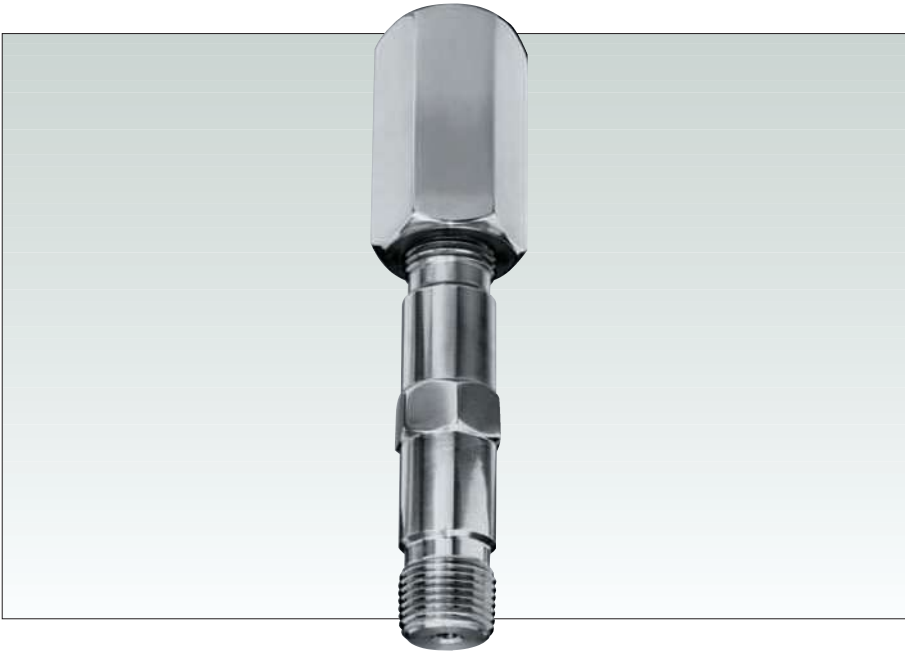

### Product Overview

Our CT7 Gauge Siphon is designed to replace the old style 'pigtail' siphon, with savings of up to 50 percent. It provides a thermal barrier between hot vapors and the pressure gauge, switch, or transmitter. The CT7 makes a valuable contribution to the technique of installing and utilizing pressure gauges on steam, Dowtherm, and other hot vapor applications, as well as providing a seal barrier between a gauge or pressure measuring device.

### Features and Benefits

- **Compact design** requires minimum space for installation.
- **Steam protection** creates a condensate barrier between the live steam process line and the pressure measurement device. The low coefficient of heat transfer allows for a predictable temperature of the pressure measurement instrument.
- **Freeze protection** forms a barrier to prevent freezing of instruments on wet air lines when the gauge siphon is filled with glycol. However, when it contains kerosene, it acts as a freeze protector for aqueous liquid service.
- **Immediate installation** of piping without instruments during construction saves time.
- **Gauge whip protection** reduces gauge whip by eliminating longer 'pigtail.' Allows closer coupling to process.

## CT7 Specifications

Use of the H7H Valve in connection with the Gauge Siphon further reduces the gauge temperature by lengthening the condensate leg. The condensate will then 'hang-up' between the valve orifice and the top of the 1/4-inch tube. That is, condensate will also occupy the lower part of the Siphon.

As vapor temperature increases, it is important to get longer condensate legs. This can be accomplished by either connecting the CT7 to an H7H or mounting two CT7 siphons in series.

### Dimensions, inches [mm]

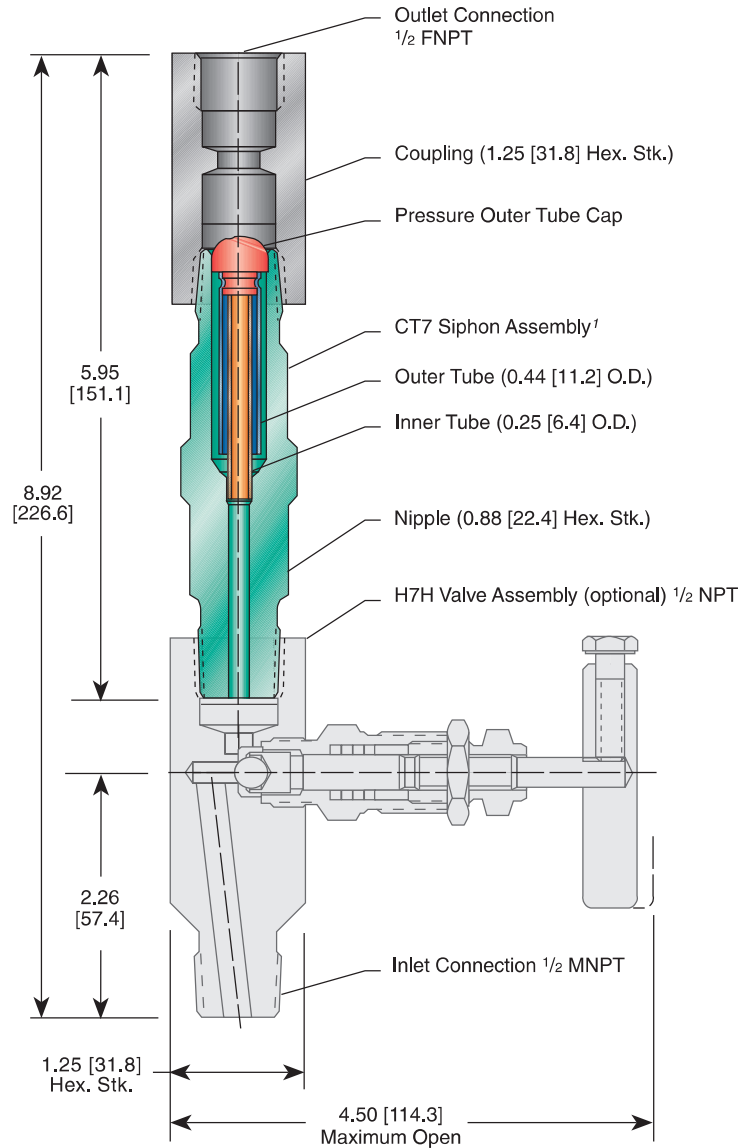

### Notes

1. Shipping weight 1.2 lb [0.55 kg] each.
2. For ordering information, request part number CT7-44, CT7C-44, CT7S-44, CT7-46, CT7C-46 or CT7S-46.
3. CS is zinc-cobalt plated to prevent corrosion.
4. For Dowtherm® applications. Dowtherm® is a registered trademark of the Dow Chemical Company.
5. Meets requirements of NACE.

### Standard Materials

Part No. <sup>2</sup>	NPT Connection		Coupling	Nipple	Inner and Outer Tubes	Maximum Pressure and Temperature Ratings	
	Outlet	Inlet					
CT7-44 <sup>3</sup>	1/2" F	1/2" M	A108	A582-303	304 SS	1500 psig @ 850°F 6000 psig @ 200°F	[103 barg @ 454°C] [414 barg @ 93°C]
CT7C-44 <sup>3,4</sup>	1/2" F	1/2" M	A108	A105	CS	1500 psig @ 850°F 6000 psig @ 200°F	[103 barg @ 454°C] [414 barg @ 93°C]
CT7S-44 <sup>5</sup>	1/2" F	1/2" M	A479-316	A479-316	316 SS	1500 psig @ 850°F 6000 psig @ 200°F	[103 barg @ 454°C] [414 barg @ 93°C]

## CT7 Heat Loss Data

### CS CT7/H7 Assembly

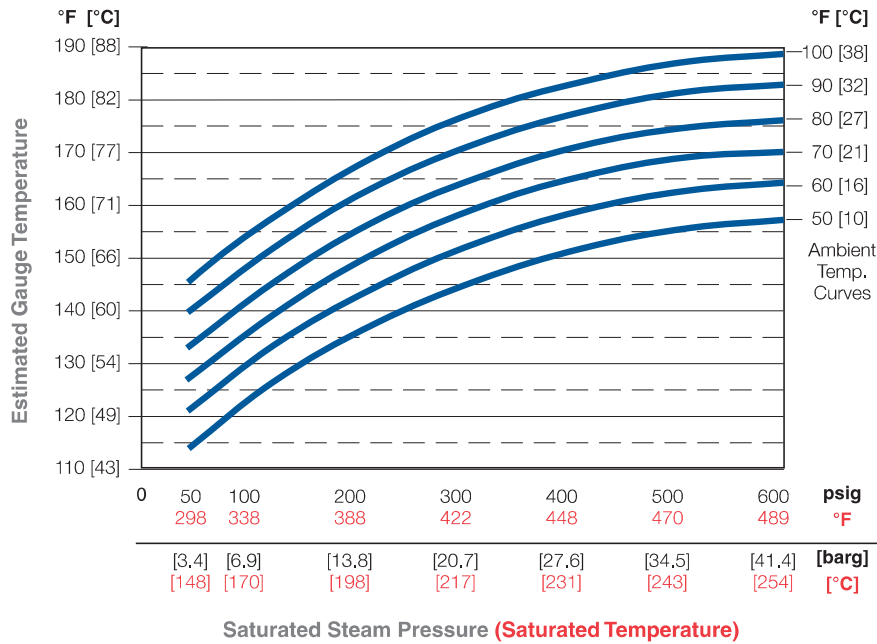

Estimated Gauge Temperature vs. Saturated Steam Pressure for Various Ambient Temperatures (CS)

### 316 SS CT7/H7 Assembly

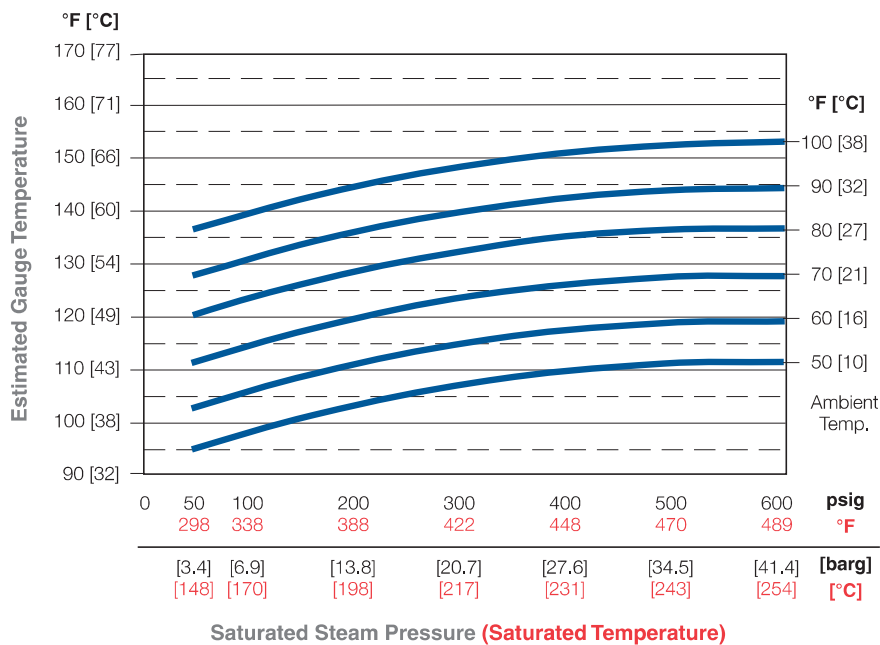

Estimated Gauge Temperature vs. Saturated Steam Pressure for Various Ambient Temperatures (316 SS)

### Using the charts

The gauge temperature of a CT7/H7 assembly can be estimated knowing the CT7/H7 material, the saturated steam condition and the ambient air temperature.

**Example:** Assume a CS CT7/H7 with 400 psig [27.6 barg] 448°F [231°C] saturated steam and 80° [27°C] ambient air. Read the CS chart up from 400 psig [27.6 barg] to the 80°F [27°C] curve, and then left to an estimated gauge temperature of 170°F [77°C].

**Note:** The estimated gauge temperature for a 316 SS CT7/H7 under the same conditions would be 135°F [57°C].

## Gauge Adapter – GA-HP



### Product Overview

Designed for use with multiport valves and 2-valve manifolds to increase site versatility, the GA-HP Swivel Gauge Adapter allows positioning of pressure gauges in any direction through 360 degrees. The GA-HP Gauge Adapter, supplied in SS and Monel®, is available in a variety of sizes and thread types for maximum flexibility. The standard types are male and female threaded and are available with NPT. Connection sizes include 1/4-inch, 3/8-inch and 1/2-inch. Suitable for pressures up to 10,000 psig [689 barg] and temperatures up to 1000°F [538°C], the GA-HP is available with trim to meet the requirements of NACE.

### Features and Benefits

- **Versatile design** available in a variety of sizes and thread types gives complete design flexibility.
- **Choice of body materials** manufactured in SS and Monel® for a wide range of applications.
- **Gauge positioning** enables easy viewing of the gauge in any direction through 360 degrees.
- **High pressure applications:** of up to 10,000 psig [689 barg] can be met.



## GA-HP Specifications

### Dimensions, inches [mm]

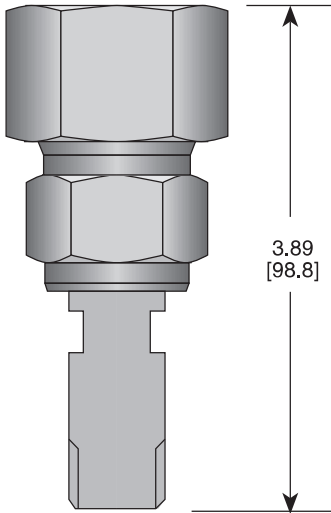

### Standard Materials<sup>1,2</sup>

Adapter	Body
SS	A479 316
Monel®	Monel® R405

### Pressure and Temperature Ratings

GA-HP	
10,000 psig @ 200°F	[689 barg @ 93°C]
1500 psig @ 1000°F	[103 barg @ 538°C]

### Notes

1. For other material requirements, please consult the factory.
2. Approximate adapter weight 0.4 lb [0.2 kg].

### Ordering Information

**GA-HP S - 4 4 - SG**

#### Materials of Construction

- S - SS
- M - Monel®

#### Inlet Connections

- 4 - 1/2-inch MNPT

#### Outlet Connections

- 4 - 1/2-inch FNPT
- 4M - 1/2-inch MNPT

#### Options

- SG - (Sour Gas) meets the requirements of NACE MR0175/ISO 15156-3 Corrigendum 2 (for Chloride conditions ≤ 50 mg/l [ppm]) and NACE MR0103-2005
- SP - Special Requirements - please specify

## Flow Check Adapter – FCA

### Product Overview

The Flow Check Adapter is designed to connect a pressure source and a static pressure measuring instrument. In the event of the instrument rupturing, the flow check adapter closes automatically as a result of the medium 'flowing.' Flow check serves as a pressure snubbing device against pressure peaks which may be damaging and also acts as a syphon protecting the instrument from the effects of hot steam by allowing a barrier of steam condensate to form. The adapter can be rotated through 360 degrees allowing the instrument to be oriented in the best position. Flow check is designed for hazardous service including toxic, flammable and high pressure duties providing extra protection for personnel and the environment.



### Features and Benefits

- **The flow check adapter seals off the flow** when activated by escaping gas or liquid.
- **Automatically resets** when flow conditions cease or the instrument is replaced.
- **Integral restricted orifice** acts as a pulsation damper and therefore reduces damage to sensitive instruments.
- **Rotatable adapter option** allows 360-degree positioning of gauges and instruments.
- **Integral syphon** for use on steam service provides a protective condensate barrier to prevent live steam from damaging instruments.
- **Robust and compact design** allows rigid installation of gauges and instruments.

### Applications

- Flow Prevention
- Pressure Snubbing
- Corrosive/Flammable/Hazardous Substances
- Gauge Syphon for Steam Service
- Oxygen Service
- Environmental Protection
- Personnel Safety
- Finished Product Contamination
- Sour Gas Service

## FCA Specifications

### Dimension, inches [mm]

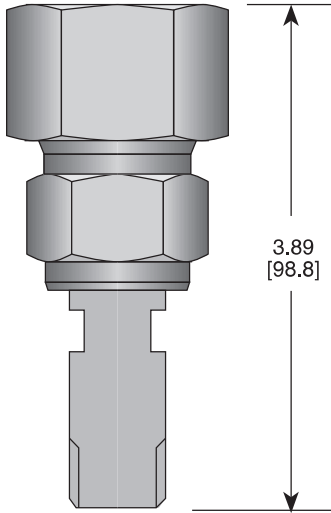

### Product Description

The FCA is available in SS with the option of Monel®. Connections are available 1/2-inch NPT male x female as standard. Suitable for pressures up to 10,000 psig [689 barg] and temperatures 1000°F [538°C], the FCA is available with trim to meet the requirements of NACE.

### Installation<sup>1</sup>

Pressure gauges or instruments may be installed directly onto the flow check adapter which in turn can be connected to the gauge/isolation valve. Alternatively, the adapter can be installed directly onto the primary/root isolation valve providing complete protection for the impulse line and subsidiary instruments and gauges.

### Standard Materials

Adapter	Body
SS	A479 316
Monel®	Monel® 400

### Pressure and Temperature Ratings

	Standard - Metal Seat (maximum)	Soft Seat Option (maximum)
10,000 psig [689 barg]	1000°F [537°C]	464°F [240°C]

### Ordering Information

**FCA S - 4 x 4 - SG**

### Materials of Construction

- S - SS
- M - Monel®

### Gauge Connection

- 4 - 1/2-inch FNPT

### Process Connection

- 4 - 1/2-inch MNPT

### Options

- OC - Oxygen cleaning
- SG - (Sour Gas) meets the requirements of NACE MR0175/ISO 15156-3 Corrigendum 2 (for Chloride conditions ≤ 50 mg/l [ppm]) and NACE MR0103-2005
- SH - Soft Seated
- SP - Special Requirements - please specify

### Notes

1. The FCA should be used in the vertical position, placing the gauge connection above the process connection.
2. Minimal leakage will occur to equalize the pressure to enable resetting the FCA when instrument has been replaced.
3. Approximate adapter weight: 0.66 lb [0.3 kg].

## **ANDERSON GREENWOOD INSTRUMENTATION PRODUCTS**

P.O. Box 944, Stafford  
Texas 77497, USA

**Telephone: 1-281-274-4400**

Fax: 1-281-240-1800

Sharp Street, Walkden  
Worsley  
Manchester, M28 3NA  
United Kingdom

**Telephone: 44-161-790-7741**

Fax: 44-161-703-1859

[www.aginstrumentation.com](http://www.aginstrumentation.com)

[www.tycoflowcontrol.com](http://www.tycoflowcontrol.com)



Tyco Flow Control (TFC) provides the information herein in good faith but makes no representation as to its comprehensiveness or accuracy. This data sheet is intended only as a guide to TFC products and services. Individuals using this data sheet must exercise their independent judgment in evaluating product selection and determining product appropriateness for their particular purpose and system requirements. TFC MAKES NO REPRESENTATIONS OR WARRANTIES, EITHER EXPRESS OR IMPLIED, INCLUDING WITHOUT LIMITATION ANY WARRANTIES OF MERCHANTABILITY OR FITNESS FOR A PARTICULAR PURPOSE WITH RESPECT TO THE INFORMATION SET FORTH HEREIN OR THE PRODUCT(S) TO WHICH THE INFORMATION REFERS. ACCORDINGLY, TFC WILL NOT BE RESPONSIBLE FOR DAMAGES (OF ANY KIND OR NATURE, INCLUDING INCIDENTAL, INDIRECT, OR CONSEQUENTIAL DAMAGES) RESULTING FROM THE USE OF OR RELIANCE UPON THIS INFORMATION. Patents and Patents Pending in the U.S. and foreign countries. Tyco reserves the right to change product designs and specifications without notice.

